

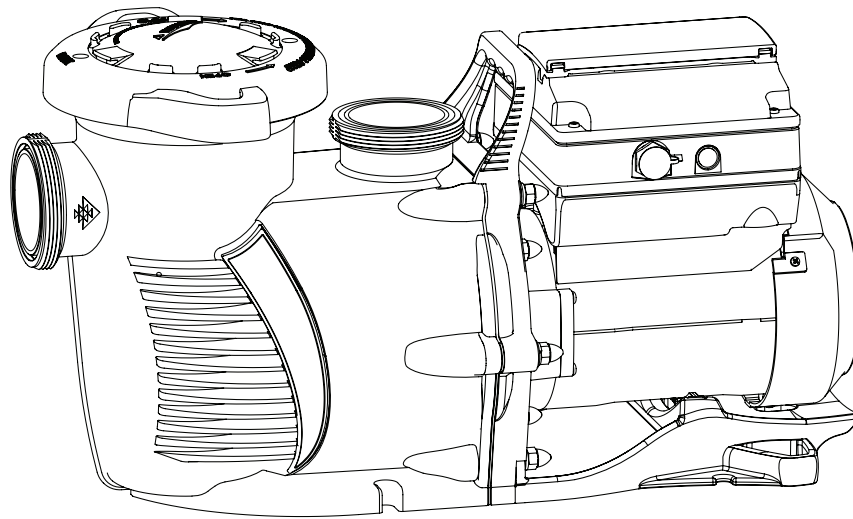

# INTELLIFLOXF<sup>®</sup> AND INTELLIPROXF<sup>®</sup> VARIABLE SPEED PUMP



## INSTALLATION AND USER'S GUIDE

IMPORTANT SAFETY INSTRUCTIONS  
*READ AND FOLLOW ALL INSTRUCTIONS*  
SAVE THESE INSTRUCTIONS

# IMPORTANT SAFETY INSTRUCTIONS



## IMPORTANT NOTICE

This guide provides installation and operation instructions for this pump. Consult Pentair with any questions regarding this equipment.

**Attention Installer:** This guide contains important information about the installation, operation and safe use of this product. This information should be given to the owner and/or operator of this equipment after installation or left on or near the pump.

**Attention User:** This manual contains important information that will help you in operating and maintaining this product. Please retain it for future reference.

### READ AND FOLLOW ALL INSTRUCTIONS SAVE THESE INSTRUCTIONS



This is the safety alert symbol. When you see this symbol on your system or in this manual, look for one of the following signal words and be alert to the potential for personal injury.

#### **DANGER**

Warns about hazards that can cause death, serious personal injury, or major property damage if ignored.

#### **WARNING**

Warns about hazards that may cause death, serious personal injury, or major property damage if ignored.

#### **CAUTION**

Warns about hazards that may or can cause minor personal injury or property damage if ignored.

#### **NOTE**

Indicates special instructions not related to hazards.

Carefully read and follow all safety instructions in this manual and on equipment. Keep safety labels in good condition; replace if missing or damaged.

When installing and using this electrical equipment, basic safety precautions should always be followed, include the following:

#### **DANGER**

FAILURE TO FOLLOW ALL INSTRUCTIONS AND WARNINGS CAN RESULT IN SERIOUS BODILY INJURY OR DEATH. **THIS PUMP SHOULD BE INSTALLED AND SERVICED ONLY BY A QUALIFIED POOL SERVICE PROFESSIONAL. INSTALLERS, POOL OPERATORS AND OWNERS MUST READ THESE WARNINGS AND ALL INSTRUCTIONS IN THE OWNER'S MANUAL BEFORE USING THIS PUMP. THESE WARNINGS AND THE OWNER'S MANUAL MUST BE LEFT WITH THE POOL OWNER.**

#### **WARNING**

Do not permit children to use this product.

#### **WARNING**

**RISK OF ELECTRICAL SHOCK.** Connect only to a branch circuit protected by a ground-fault circuit-interrupter (GFCI). Contact a qualified electrician if you cannot verify that the circuit is protected by a GFCI.

#### **WARNING**

This unit must be connected only to a supply circuit that is protected by a ground-fault circuit-interrupter (GFCI). Such a GFCI should be provided by the installer and should be tested on a routine basis. To test the GFCI, push the test button. The GFCI should interrupt power. Push the reset button. Power should be restored. If the GFCI fails to operate in this manner, the GFCI is defective. If the GFCI interrupts power to the pump without the test button being pushed, a ground current is flowing, indicating the possibility of an electric shock. Do not use this pump. Disconnect the pump and have the problem corrected by a qualified service representative before using.

#### **CAUTION**

This pump is for use with permanent swimming pools and may also be used with hot tubs and spas if so marked. Do not use with storable pools. A permanently-installed pool is constructed in or on the ground or in a building such that it cannot be readily disassembled for storage. A storable pool is constructed so that it is capable of being readily disassembled for storage and reassembled to its original integrity.

## General Warnings

- Never open the inside of the drive motor enclosure. There is a capacitor bank that holds a 230 VAC charge even when there is no power to the unit.
- The pump is not submersible.
- The pump is capable of high flow rates; use caution when installing and programming to limit pumps performance potential with old or questionable equipment.
- Code requirements for electrical connection differ from country to country, state to state, as well as local municipalities. Install equipment in accordance with the National Electrical Code and all applicable local codes and ordinances.
- Before servicing the pump; switch OFF power to the pump by disconnecting the main circuit to the pump.
- This appliance is not intended for use by persons (including children) of reduced physical, sensory or mental capabilities, or lack of experience and knowledge, unless they have been given supervision or instruction concerning the use of the appliance by a person responsible for their safety.

#### **DANGER**

**SUCTION ENTRAPMENT HAZARD: STAY OFF THE MAIN DRAIN AND AWAY FROM ALL SUCTION OUTLETS! THIS PUMP IS NOT EQUIPPED WITH SAFETY VACUUM RELEASE SYSTEM (SVRS) PROTECTION AND DOES NOT PROTECT AGAINST BODY OR LIMB ENTRAPMENTS, DISEMBOWELMENTS (WHEN A PERSON SITS ON A BROKEN OR UNCOVERED POOL DRAIN) OR HAIR ENTANGLEMENTS.**



THIS PUMP PRODUCES HIGH LEVELS OF SUCTION AND CREATES A STRONG VACUUM AT THE MAIN DRAIN AT THE BOTTOM OF THE BODY OF WATER. THIS SUCTION IS SO STRONG THAT IT CAN TRAP ADULTS OR CHILDREN UNDER WATER IF THEY COME IN CLOSE PROXIMITY TO A DRAIN OR A LOOSE OR BROKEN DRAIN COVER OR GRATE.

THE USE OF UNAPPROVED COVERS OR ALLOWING USE OF THE POOL OR SPA WHEN COVERS ARE MISSING, CRACKED OR BROKEN CAN RESULT IN BODY OR LIMB ENTRAPMENT, HAIR ENTANGLEMENT, BODY ENTRAPMENT, EVisCERATION AND/OR DEATH.

#### The suction at a drain or outlet can cause:

**Limb Entrapment:** When a limb is sucked or inserted into an opening resulting in a mechanical bind or swelling. This hazard is present when a drain cover is missing, broken, loose, cracked or not properly secured.

**Hair Entanglement:** When the hair tangles or knots in the drain cover, trapping the swimmer underwater. This hazard is present when the flow rating of the cover is too small for the pump or pumps.

**Body Entrapment:** When a portion of the body is held against the drain cover trapping the swimmer underwater. This hazard is present when the drain cover is missing, broken or the cover flow rating is not high enough for the pump or pumps.

**EVisCeration/Disembowelment:** When a person sits on an open pool (particularly a child wading pool) or spa outlet and suction is applied directly to the intestines, causing severe intestinal damage. This hazard is present when the drain cover is missing, loose, cracked, or not properly secured.

**Mechanical Entrapment:** When jewelry, swimsuit, hair decorations, finger, toe or knuckle is caught in an opening of an outlet or drain cover. This hazard is present when the drain cover is missing, broken, loose, cracked, or not properly secured.

**NOTE: ALL SUCTION PLUMBING MUST BE INSTALLED IN ACCORDANCE WITH THE LATEST NATIONAL AND LOCAL CODES, STANDARDS AND GUIDELINES.**

# IMPORTANT SAFETY INSTRUCTIONS

## **⚠ WARNING** TO MINIMIZE THE RISK OF INJURY DUE TO SUCTION ENTRAPMENT HAZARD:

- A properly installed and secured ANSI/ASME A112.19.8 approved anti-entrapment suction cover must be used for each drain.
- Each suction cover must be installed at least three (3') feet apart, as measured from the nearest point to nearest point.
- Regularly inspect all covers for cracks, damage and advanced weathering.
- If a cover becomes loose, cracked, damaged, broken or is missing, replace with an appropriate certified cover.
- Replace drain covers as necessary. Drain covers deteriorate over time due to exposure to sunlight and weather.
- Avoid getting hair, limbs or body in close proximity to any suction cover, pool drain or outlet.
- Disable suction outlets or reconfigure into return inlets.

**⚠ WARNING** The pump can produce high levels of suction within the suction side of the plumbing system. These high levels of suction can pose a risk if a person comes within the close proximity of the suction openings. A person can be seriously injured by this high level of vacuum or may become trapped and drown. It is absolutely critical that the suction plumbing be installed in accordance with the latest national and local codes for swimming pools.

**⚠ WARNING** A clearly labeled emergency shut-off switch for the pump must be in an easily accessible, obvious place. Make sure users know where it is and how to use it in case of emergency.

**The Virginia Graeme Baker (VGB) Pool and Spa Safety Act** creates new requirements for owners and operators of commercial swimming pools and spas.

Commercial pools or spas constructed on or after December 19, 2008, shall utilize:

(A) A multiple main drain system without isolation capability with suction outlet covers that meet ASME/ANSI A112.19.8a Suction Fittings for Use in Swimming Pools, Wading Pools, Spas, and Hot Tubs and either:

(i) A safety vacuum release system (SVRS) meeting ASME/ANSI A112.19.17 Manufactured Safety Vacuum Release systems (SVRS) for Residential and Commercial Swimming Pool, Spa, Hot Tub, and Wading Pool Suction Systems and/or ASTM F2387 Standard Specification for Manufactured Safety Vacuum Release Systems (SVRS) for Swimming pools, Spas and Hot Tubs or

(ii) A properly designed and tested suction-limiting vent system or

(iii) An automatic pump shut-off system.

Commercial pools and spas constructed prior to December 19, 2008, with a single submerged suction outlet shall use a suction outlet cover that meets ASME/ANSI A112.19.8a and either:

(A) A SVRS meeting ASME/ANSI A112.19.17 and/or ASTM F2387, or

(B) A properly designed and tested suction-limiting vent system, or

(C) An automatic pump shut-off system, or

(D) Disabled submerged outlets, or

(E) Suction outlets shall be reconfigured into return inlets.

## **⚠ CAUTION** For Installation of Electrical Controls at Equipment Pad (ON/OFF Switches, Timers and Automation Load Center)



Install all electrical controls at equipment pad, such as on/off switches, timers, and control systems, etc. to allow the operation (startup, shut-down, or servicing) of any pump or filter so the user does not place any portion of his/her body over or near the pump strainer lid, filter lid or valve closures. This installation should allow the user enough space to stand clear of the filter and pump during system start-up, shut down or servicing of the system filter.

## **⚠ DANGER** HAZARDOUS PRESSURE: STAND CLEAR OF PUMP AND FILTER DURING START UP.



Circulation systems operate under high pressure. When any part of the circulating system (i.e. locking ring, pump, filter, valves, etc.) is serviced, air can enter the system and become pressurized. Pressurized air can cause the pump housing cover, filter lid, and valves to violently separate which can result in severe personal injury or death. Filter tank lid and strainer cover must be properly secured to prevent violent separation. Stand clear of all circulation system equipment when turning on or starting up pump. Before servicing equipment, make note of the filter pressure. Be sure that all controls are set to ensure the system cannot inadvertently start during service. Turn off all power to the pump. **IMPORTANT: Place filter manual air relief valve in the open position and wait for all pressure in the system to be relieved.**

Before starting the system, fully open the manual air relief valve and place all system valves in the "open" position to allow water to flow freely from the tank and back to the tank. Stand clear of all equipment and start the pump.

**IMPORTANT: Do not close filter manual air relief valve until all pressure has been discharged from the valve and a steady stream of water appears.** Observe filter pressure gauge and be sure it is not higher than the pre-service condition.

### General Installation Information

- All work must be performed by a qualified service professional, and must conform to all national, state, and local codes.
- Install to provide drainage of compartment for electrical components.
- These instructions contain information for a variety of pump models and therefore some instructions may not apply to a specific model. All models are intended for use in swimming pool applications. The pump will function correctly only if it is properly sized to the specific application and properly installed.

**⚠ WARNING** Pumps improperly sized or installed or used in applications other than for which the pump was intended can result in severe personal injury or death. These risks may include but not be limited to electric shock, fire, flooding, suction entrapment or severe injury or property damage caused by a structural failure of the pump or other system component.

**Pumps and replacement motors that are single speed and one (1) Total HP or greater cannot be sold, offered for sale, or installed in a residential pool for filtration use in California, Title 20 CCR sections 1601-1609.**

## CUSTOMER SERVICE / TECHNICAL SUPPORT

If you have questions about ordering Pentair replacement parts, and pool products, please contact:

### Customer Service and Technical Support, USA

(8 A.M. to 4:30 P.M. — Eastern/Pacific Times)

Phone: (800) 831-7133

Fax: (800) 284-4151

### Web site

Visit [www.pentair.com](http://www.pentair.com) for information about Pentair products.\*

### Sanford, North Carolina (8 A.M. to 4:30 P.M. ET)

Phone: (919) 566-8000

Fax: (919) 566-8920

### Moorpark, California (8 A.M. to 4:30 P.M. PT)

Phone: (805) 553-5000 (Ext. 5591)

Fax: (805) 553-5515

## TABLE OF CONTENTS

<b>Important Safety Instructions</b> .....	<b>i</b>	<b>External Control</b> .....	<b>12</b>
<b>Pump Overview</b> .....	<b>1</b>	<b>Features</b> .....	<b>13</b>
Drive Assembly and Control Panel	1	Time Out	13
External Control	1	Quick Clean/Only High Speed Override	13
Motor Features	1	<b>Priming</b> .....	<b>13</b>
Drive Features	1	Priming Features	14
<b>Installation</b> .....	<b>2</b>	Setting Priming Features	15
Location	2	Disabling Priming with an Automation System	15
Piping	2	<b>Thermal Mode</b> .....	<b>16</b>
Electrical Requirements	2	<b>Connecting to an Automation System</b> .....	<b>17</b>
Optional Keypad Relocation Kit	2	External Control with IntelliComm	17
Fittings and Valves	2	Connecting to EasyTouch and IntelliTouch Systems	17
Electrical Installation	3	Connecting to SunTouch Systems	19
Wiring, Grounding and Bonding	3	<b>Maintenance</b> .....	<b>20</b>
<b>Operating the Pump</b> .....	<b>4</b>	Cleaning the Pump Strainer Basket	20
Priming the Pump	4	Winterizing	20
Using the Control Panel	5	Motor and Drive Care	21
Stopping and Starting the Pump	6	Pump Disassembly	21
Adjust and Save a Pump Speed	6	Shaft Seal Replacement	22
Operating the Pump at Preset Speeds	6	Pump Reassembly	22
Pump Operating Modes	6	Drive Assembly Removal and Installation	23
Control Panel Menu Guide	7	<b>Troubleshooting</b> .....	<b>24</b>
<b>Pump Settings</b> .....	<b>8</b>	Alerts and Warnings	24
Set Date and Time	8	Troubleshooting Chart	25
Set Time & AM/PM or 24 Hour Clock	8	<b>Replacement Parts</b> .....	<b>27</b>
Set Min/Max Speeds	8	Illustrated Parts List	27
Pump Address	8	Pump Performance Curves	28
Set Screen Contrast	9	Electrical Specifications	28
Set Control Panel Language	9	Pump Dimensions	28
Set Temperature Unit	9	Pump Menu Quick Reference Guide	29
Password Protection	9		
Setting Password	10		
<b>Setting Speeds 1-8</b> .....	<b>10</b>		
Pump Operating Modes	10		
Setting Speeds in Manual Mode	11		
Setting Speeds in Egg-Timer Mode	11		
Setting Speeds 1-8 in Schedule Mode	11		

\* Translated versions of this manual are available online at / La versión en español de este manual del producto, se puede encontrar en línea a / La version française de ce manuel est disponible à :

[https://www.pentair.com/en/products/pool-spa-equipment/pool-pumps/intellifloxf\\_variablespeedpump.html](https://www.pentair.com/en/products/pool-spa-equipment/pool-pumps/intellifloxf_variablespeedpump.html)

[https://www.pentair.com/en/products/pool-spa-equipment/pool-pumps/intelliproxf\\_variablespeedpump.html](https://www.pentair.com/en/products/pool-spa-equipment/pool-pumps/intelliproxf_variablespeedpump.html).

# PUMP OVERVIEW

The IntelliFloXF® Variable Speed Pump can be programmed to run at specific speeds and time intervals for maximum operating efficiency and energy conservation for a variety of inground pools.

- The pump can operate from 450 RPM to 3450 RPM with four preset speeds of 750, 1500, 2350 and 3110 RPM
- The pump can be adjusted from the control panel to run at any speed between 450 RPM to 3450 RPM for different applications
- Up to 8 programmable speeds
- Pump control panel alarm LED and error messages warn the user against under and over voltage, high temperature, over current and freezing
- Communicates with EasyTouch, IntelliTouch or SunTouch control systems or an IntelliComm communication center via a two-wire RS-485 cable connection
- Programmable priming mode with automatic detection of prime for easy start-up
- Compatible with most cleaning systems, filters, and jet action spas
- WEF [5.6](#) THP [3.95](#)

## Drive Assembly and Control Panel

The IntelliFlo pump drive is designed to produce maximum motor operational efficiency. The drive controls the motor's rotational speed by controlling the frequency of the supplied current. It also protects the motor and pump from operating outside of their intended operating parameters.

The control panel can be mounted on the pump in four different directions in order to provide the user the best access. The control panel can also be mounted in a more convenient location with the help of the keypad relocation kit (P/N 356904Z [Almond] or 356905Z [Black]).

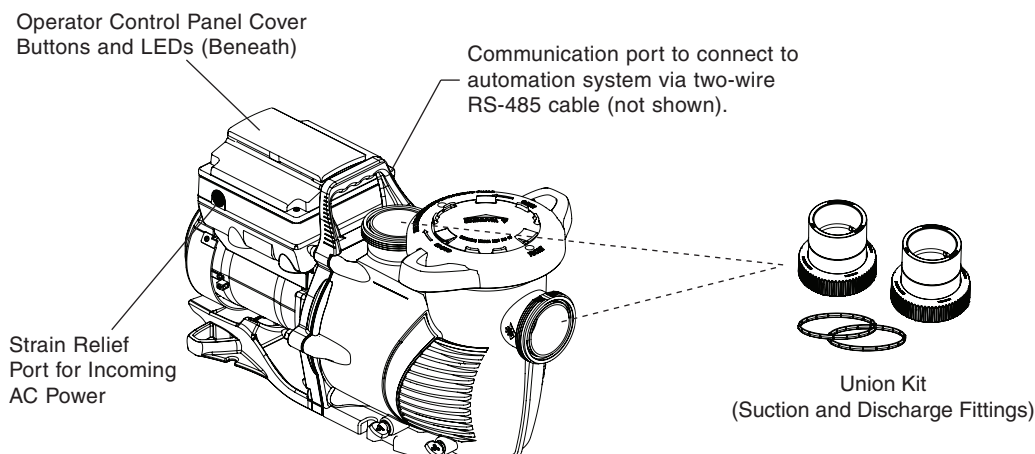

## External Control

IntelliTouch®, EasyTouch®, SunTouch® Control Systems and IntelliComm® Communication Centers can remotely control the IntelliFlo pump. The pump's communications address and other functions are accessible from the pump's control panel.

- RS-485 communication cable included
- IntelliTouch systems control 8 IntelliFlo pumps using 8 speeds per pump.
- EasyTouch systems control 2 IntelliFlo pumps using 8 speeds per pump.
- SunTouch systems control one IntelliFlo pump using 8 speeds.
- IntelliComm systems control one IntelliFlo pump using the 4 External Control programs.

## Motor Features

- High Efficiency Permanent Magnet Synchronous Motor (PMSM)
- Superior speed control
- Operates at lower temperatures due to high efficiency
- Designed to withstand outdoor environment
- Totally Enclosed Fan Cooled (TEFC) Motor
- 56 Square Flange
- Low noise

## Drive Features

- Active Power Factor Correction
- Rotatable Keypad
- Easy Overhead Wiring
- High Drive Operational Efficiency

# INSTALLATION

Only a qualified plumbing professional should install the IntelliFloXF® and IntelliProXF® Variable Speed Pumps. Refer to “Important Safety Instructions” on pages i - ii for additional installation and safety information.

## Location

**Note:** Do not install this pump within an outer enclosure or beneath the skirt of a hot tub or spa unless marked accordingly.

**Note:** Ensure that the pump is mechanically secured to the equipment pad.

### Be sure the pump location meets the following requirements:

1. Install the pump as close to the pool or spa as possible. To reduce friction loss and improve efficiency, use short, direct suction and return piping.
2. Install a minimum of 5 ft. (1.5 m) from the inside wall of the pool and spa. Canadian installations require a minimum of 9.8 ft. (3 m) from the inside wall of the pool.
3. Install the pump a minimum of 3 ft. (0.9 m) from the heater outlet.
4. Do not install the pump more than 10 ft. (3.1 m) above the water level.
5. Install the pump in a well ventilated location protected from excess moisture (i.e. rain gutter downspouts, sprinklers, etc.).
6. Install the pump with a rear clearance of at least 3 inches (7.6 cm) so that the motor can be removed easily for maintenance and repair. See **Figure 1**.

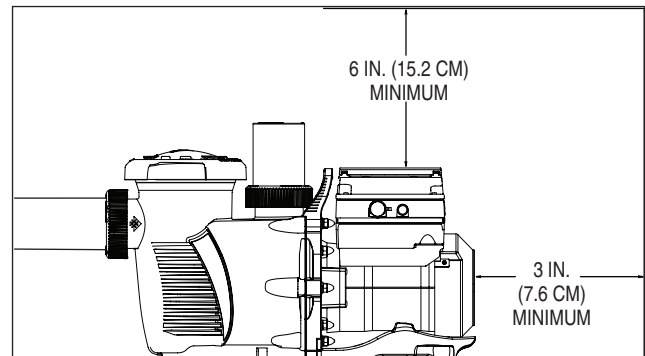

**Figure 1:** Pump Rear and Vertical Clearance

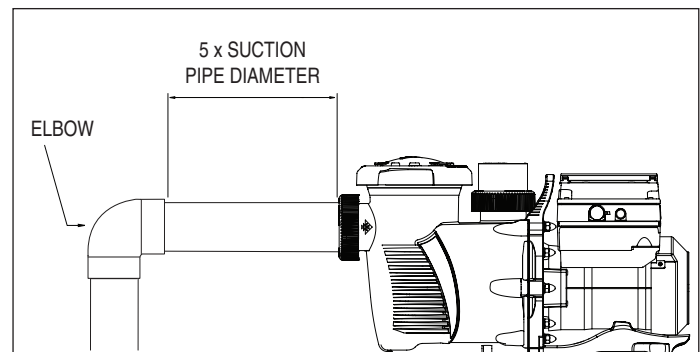

**Figure 2:** Recommended Piping

## Piping

1. For improved pool plumbing, it is recommended to use a larger pipe size.
2. Piping on the suction side of the pump should be the same or larger than the return line diameter.
3. Plumbing on the suction side of the pump should be as short as possible.
4. For most installations Pentair recommends installing a valve on both the pump suction and return lines so that the pump can be isolated during routine maintenance. However, we also recommend that a valve, elbow or tee installed in the suction line should be no closer to the front of the pump than five times the suction line diameter. See **Figure 2**.

**Example:** A 2.5 inch pipe requires a 12.5 in. (31.8 cm) straight run in front of the suction inlet of the pump. This will help the pump prime faster and last longer.

**Note:** DO NOT install 90° elbows directly into the pump inlet or outlet.

## Electrical Requirements

- Install all equipment in accordance with the National Electrical code and all applicable local codes and ordinances.
- A means for disconnection must be incorporated in the fixed wiring in accordance with the wiring rules.

## Optional Keypad Relocation Kit

In special cases when the user lacks easy or convenient access to the pump, a Keypad Relocation Kit (P/N 356904Z [Almond] or 356905Z [Black]) may be purchased from your local pool equipment supplier. This kit allows the user to remove the keypad cover from the top of the drive and mount the keypad in a fixed location with better access.

For installation instructions refer to the *Keypad Relocation Kit Installation Instructions* provided with the kit.

## Fittings and Valves

1. Do not install 90° elbows directly into pump inlet.
2. Flooded suction systems should have gate valves installed on suction and discharge pipes for maintenance, however, the suction gate valve should be no closer than five times the suction pipe diameter as described in this section.
3. Use a check valve in the discharge line when using this pump for any application where there is significant height to the plumbing after the pump.
4. Be sure to install check valves when plumbing in parallel with another pump. This helps prevent reverse rotation of the impeller and motor.

## Electrical Installation

### ⚠ WARNING



**RISK OF ELECTRICAL SHOCK OR ELECTROCUTION.** This pump must be installed by a licensed or certified electrician or a qualified service professional in accordance with the National Electrical Code and all applicable local codes and ordinances. Improper installation will create an electrical hazard which could result in death or serious injury to users, installers, or others due to electrical shock, and may also cause damage to property.

**Always disconnect power to the pump at the circuit breaker before servicing the pump. Failure to do so could result in death or serious injury to service people, users or others due to electric shock.**

Read all servicing instructions before working on the pump.

**Note:** ALWAYS reinstall the drive lid onto the field wiring compartment when leaving the pump unsupervised during servicing. This will prevent foreign matter (i.e. rainwater, dust, etc.) from accumulating in the drive.

**Note:** When connecting the pump to an automation system (IntelliTouch®, EasyTouch®, SunTouch® Control Systems and IntelliComm® Communication Center), continuous power must be supplied to the pump by connecting it directly to the circuit breaker. When using an automation system, be sure that no other lights or appliances are on the same circuit.

### Wiring

1. Be sure all electrical breakers and switches are turned off before wiring motor.

### ⚠ WARNING

**STORED CHARGE** - Wait at least 60 seconds before servicing.

2. Be sure that the supply voltage meets the requirements listed on the motor nameplate. If these requirements are not met, permanent motor damage may occur.
3. For wiring sizes and general guidelines for proper electrical installation, please follow the specifications defined in the National Electric Code and any local codes as required.
4. Use strain relief and be sure all electrical connections are clean and tight.
5. Cut the wires to the appropriate length so they do not overlap or touch when connected.
6. Reinstall the keypad cover after wiring the pump by plugging the cover back into the drive wiring connection and re-seating the keypad cover in the desired orientation with the four corner screws.

**Note:** Ensure that the keypad cable is not pinched between the drive and keypad cover during re-seating.

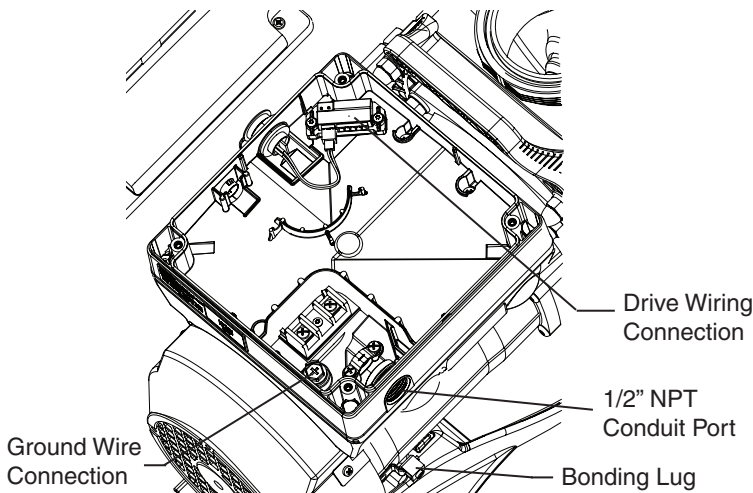

**Field Wiring Compartment**

### Grounding

1. Permanently ground the motor using the green ground screw, as shown below. Use the correct wire size and type specified by National Electrical Code. Be sure the ground wire is connected to an electrical service ground.
2. The pump should be permanently connected to either a circuit breaker, 2-pole timer or 2-pole relay.

**Note:** If AC power is supplied by a GFCI circuit breaker, the pump should be wired on its own independent circuit **unless the pump is operated in tandem with a Pentair salt chlorine generator.**

### Bonding

1. Bond the motor to the structure in accordance with the National Electrical Code. Use a solid copper bonding conductor not smaller than 8 AWG. For Canadian installations, a 6 AWG or larger solid copper bonding conductor is required. Run a wire from the external bonding screw or lug to the bonding structure.
2. Connect the wire from the accessible bonding lug on the motor to all metal parts of the swimming pool, spa, or hot tub structure and to all electrical equipment, metal conduit, and metal piping within 5 ft. (1.5 m) of the inside walls of the swimming pool, spa, or hot tub. Run a wire from the external bonding screw or lug to the bonding structure.

**Note:** When the pump is started and stopped by removing power with a relay or timer, a two-pole device should be used to apply and remove power to both POWER LINE TERMINALS.

*Pentair offers 2-Pole 20 Amp GFCI breakers (P/N PA220GF) which offer 6 milliamp personnel protection while meeting 2008 to current NEC Standards for Pool Pumps.*

## OPERATING THE PUMP

**NOTE:** Speed 1 is the default filtration speed.

**NOTE:** When setting up the pump, the user must set the pump's internal clock and establish an operation schedule by following the steps in this manual. Please refer to user's guide sections: 'Set Time' (page 8) and 'Set Speeds 1-8 in Schedule Mode' (page 11) to schedule a time to run the pump.

**CAUTION** This pump is shipped with Priming mode ENABLED. Unless the Priming settings are changed in the menu, **be aware that the pump will speed up to the maximum speed when the pump is powered on for the first time, and the Start/Stop button is pressed.** To change the maximum speed of the pump, refer to page 8.

**Before turning the pump ON, be sure the following conditions are met:**

1. Open filter air relief valve.
2. Open valves.
3. Pool return is completely open and clear of any blockages.
4. Water in the pump basket.
5. Stand clear of the filter or other pressurized vessels.

### Priming the Pump

Prime the pump before starting the pump for the first time. To avoid permanent damage to the pump, remove the lid and fill the basket with water. The pump basket must be filled with water before initial start up or after servicing.

**Follow the steps below to prime the pump for start up:**

1. Press **Start/Stop** to stop the pump. Disconnect the pump main power supply and communication cable.
2. Close all valves in suction and discharge pipes. Relieve all pressure from the system.
3. Remove the pump lid and locking ring.
4. Fill the pump strainer pot with water.
5. Reassemble the pump lid and locking ring onto the strainer basket. The pump is now ready to prime.
6. Open all valves in suction and discharge pipes.
7. Open the filter air relief valve and stand clear of the filter.
8. Connect power to the pump. Be sure green power light is on.
9. Press **Start/Stop** to start the pump. The pump will enter into priming mode (if enabled) and speed up to the maximum speed set in the pump menu settings.
10. When water comes out of the filter air relief valve, close the valve. The system should now be free of air and recirculating water to and from the pool.
11. Do not allow your pump to run longer than 30 minutes time without developing full flow. If the pump does not prime, check your priming settings on the control panel or see the *Troubleshooting* section on pages 24-26.

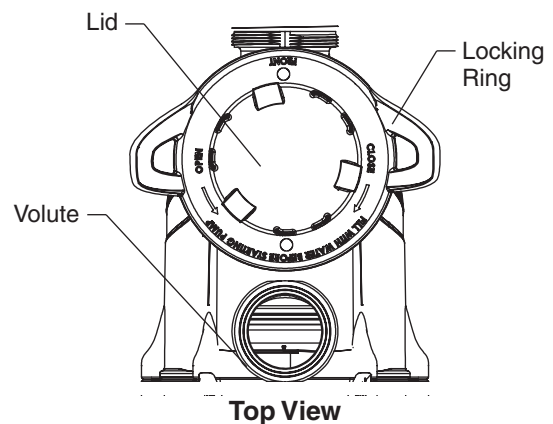

#### Priming Features

The default priming setting is ENABLED. The pump also allows you to set the following from the operator control panel:

- Priming speed
- Priming range (1-10)
- Priming delay

*Set up instructions on page 15.*

**CAUTION** Do not add chemicals to the system directly in front of pump suction. Adding undiluted chemicals may damage the pump and will void the warranty.

**CAUTION** This is a variable speed pump. Typically the lower speeds are used for filtration and heating. The higher speeds can be used for spa jets, water features, and priming.

**CAUTION** DO NOT run the pump dry. If the pump is run dry, the mechanical seal will be damaged and the pump will start leaking. If this occurs, the damaged seal must be replaced. ALWAYS maintain proper water level in your pool (half way up skimmer opening). If the water level falls below the skimmer opening, the pump will draw air through the skimmer, losing the prime and causing the pump to run dry, resulting in a damaged seal. Continued operation in this manner could cause a loss of pressure, resulting in damage to the pump case, impeller and seal and may cause property damage and personal injury.



## Using the Control Panel

Use the operator control panel to start and stop the pump, program, set, and change speeds (RPM), and access pump features and settings.

### Controls and LEDs on Keypad:

- ① **Button 1:** Press to select Speed 1 (750 RPM). LED on indicates Speed 1 is active.
- ② **Button 2:** Press to select Speed 2 (1500 RPM). LED on indicates Speed 2 is active.
- ③ **Button 3:** Press to select Speed 3 (2350 RPM). LED on indicates Speed 3 is active.
- ④ **Button 4:** Press to select Speed 4 (3110 RPM). LED on indicates Speed 4 is active.
- ⑤ **Back:** Goes one step back in menu; exits without saving current setting.
- ⑥ **Save:** Saves current menu item setting. When a parameter has been adjusted the "Save?" icon will be displayed.
- ⑦ **Menu:** Accesses the menu items when and if the pump is stopped.
- ⑧ **Select:** Press to select the currently displayed option on the screen.
- ⑨ **Arrow buttons:**
  - **Up arrow:** Move one level up in the menu or increase a digit when editing a setting.
  - **Down arrow:** Move one level down in the menu or decrease a digit when editing a setting.
  - **Left arrow:** Move cursor left one digit when editing a setting.
  - **Right arrow:** Move cursor right one digit when editing a setting.
- ⑩ **Quick Clean:** Pump increases to a higher RPM (for vacuuming, cleaning, adding chemicals, etc.). LED light is on when active.
- ⑪ **Time Out:** Allow the pump to remain in a stopped state for a set period of time before resuming normal operation. LED is on when active.
- ⑫ **Start/Stop button:** To start or stop the pump. When LED is on, the pump is running or in a mode to start automatically.
- ⑬ **Reset button:** Reset alarm or alert.
- ⑭ **LEDs:**
  - ⚡ **On:** Green light when pump is powered on.
  - ! **Warning:** On if warning condition is present.
  - 🔔 **Alarm:** Red LED on if alarm condition occurs. See *Alerts and Warnings* on page 24.
- ⑮ **Control Panel LCD Screen:**
  - **Line 1:** Key icon indicates password protection mode is active. If password protect is not enabled, no key icon is displayed. Also shows current time of day. Active cursors display when arrow key input is available.
  - **Line 2:** Displays current pump speed (RPM).
  - **Line 3:** Countdown time and watts
  - **Line 4:** Current pump status and current feature. "Save?" will display on this line when a parameter adjustment can be saved.

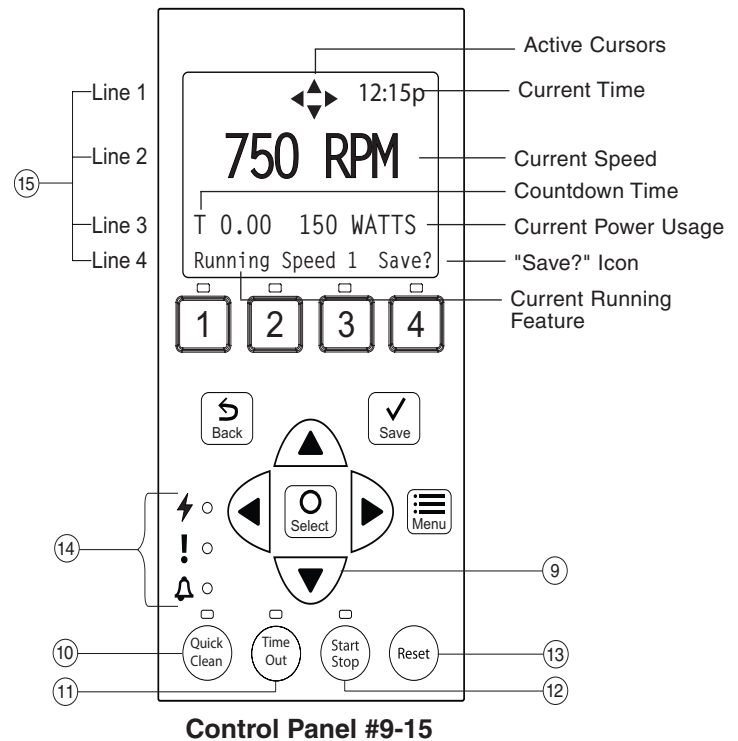
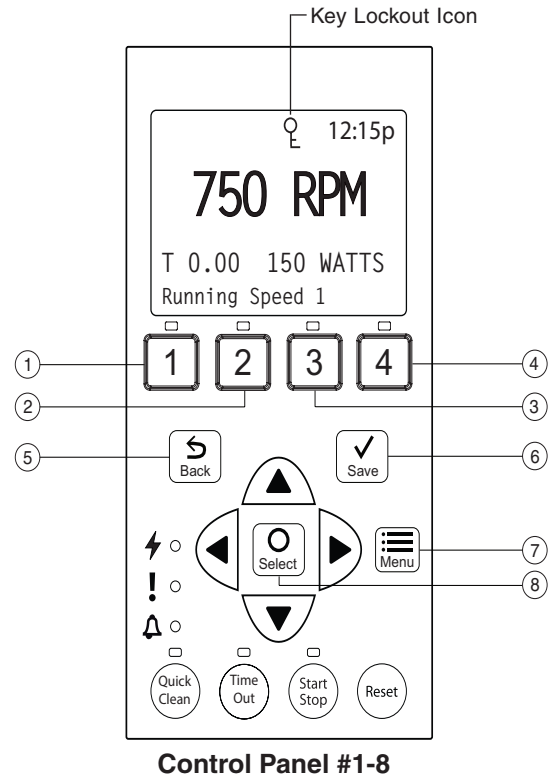

**Note:** Always close the keypad cover after using the keypad.

**Note:** Using screwdrivers or pens to program the pump will damage the keypad overlay. Use your fingers only when programming the pump.

## Stopping and Starting the Pump

### Starting the Pump

1. Be sure the pump is powered on and the green power LED is on.
2. Select one of the speed buttons, then press the **Start/Stop** button (LED on) to start the pump. The pump will go into priming mode if priming feature is enabled.

### Stopping the Pump

1. Press **Start/Stop** to stop the pump.  
When servicing equipment (filters, heaters, chlorinators etc.), disconnect the communication cable, and switch OFF circuit breaker to remove power from the pump.

**Note:** The pump can automatically restart if the communication cable is connected.

## Adjusting and Saving a Pump Speed

1. While the pump is running, press the **Up** or **Down** arrow to adjust to desired speed setting.
2. Press and hold down a **Speed** button (1-4) for 3 seconds to save speed to the button or press **Save** to save the speed.

## Operating the Pump at Preset Speeds

The pump is programmed with four default speeds of 750, 1500, 2350 and 3110 RPM. Speed buttons 1-4 are for each of the preset speeds as shown below.

1. Be sure the pump is powered on and the green power LED is on.
2. Press the **Speed** button (1- 4) corresponding to the desired preset speed and release quickly. The LED above the button will turn on.
3. Press **Start/Stop**. The pump will quickly change to the selected preset speed.

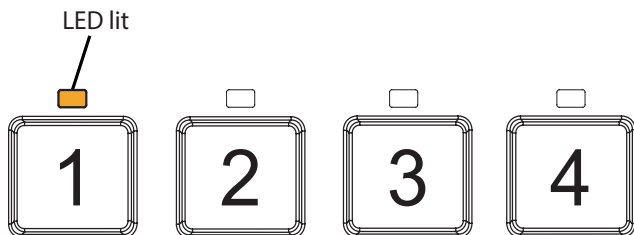

## Pump Operating Modes

The pump can be programmed in three different modes:

**Manual, Schedule, and Egg Timer:** *Speeds 1-4 can be programmed in all three modes. Speeds 5-8 can only be programmed in Schedule mode since there are no buttons on the control panel for Speeds 5-8. The default setting for Speeds 5-8 is “Disabled”.*

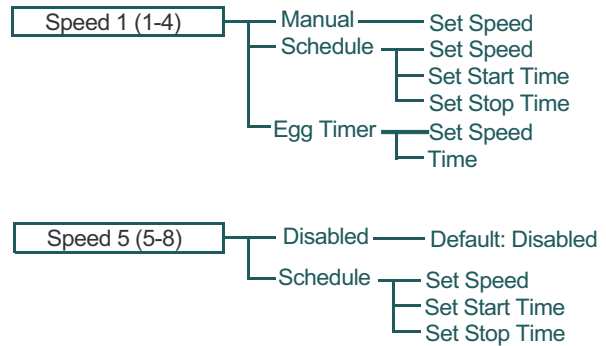

Speed Menu Tree Options

### Manual

Assigns a speed to one of the four Speed buttons on the control panel. This mode can only be used for speeds 1-4. To operate in Manual mode, press one of the four speed buttons and then press the **Start/Stop** button. The pump will run the assigned speed for that speed button.

### Egg Timer

Speeds 1-4 can be programmed to run at a certain speed and for a duration of time once a speed button is pressed.

Speeds 3 and 4 are Egg Timers by default. This prevents the pump from running at a speed higher than half of the maximum speed indefinitely. If you desire a different method of operation, speeds 3 and 4 can be changed to Manual mode in the control menu.

To operate in Egg Timer mode, press a speed button and then press **Start/Stop**. The pump will run that speed for the set amount of time and then turn off.

### Schedule

Program speeds 1-8 start and stop at a specific time during a 24 hour period. Speeds programmed in Schedule mode will override any manually selected speed (speeds set by manually pressing any of the speed buttons on the control panel).

# Control Panel: Pump Menu Guide

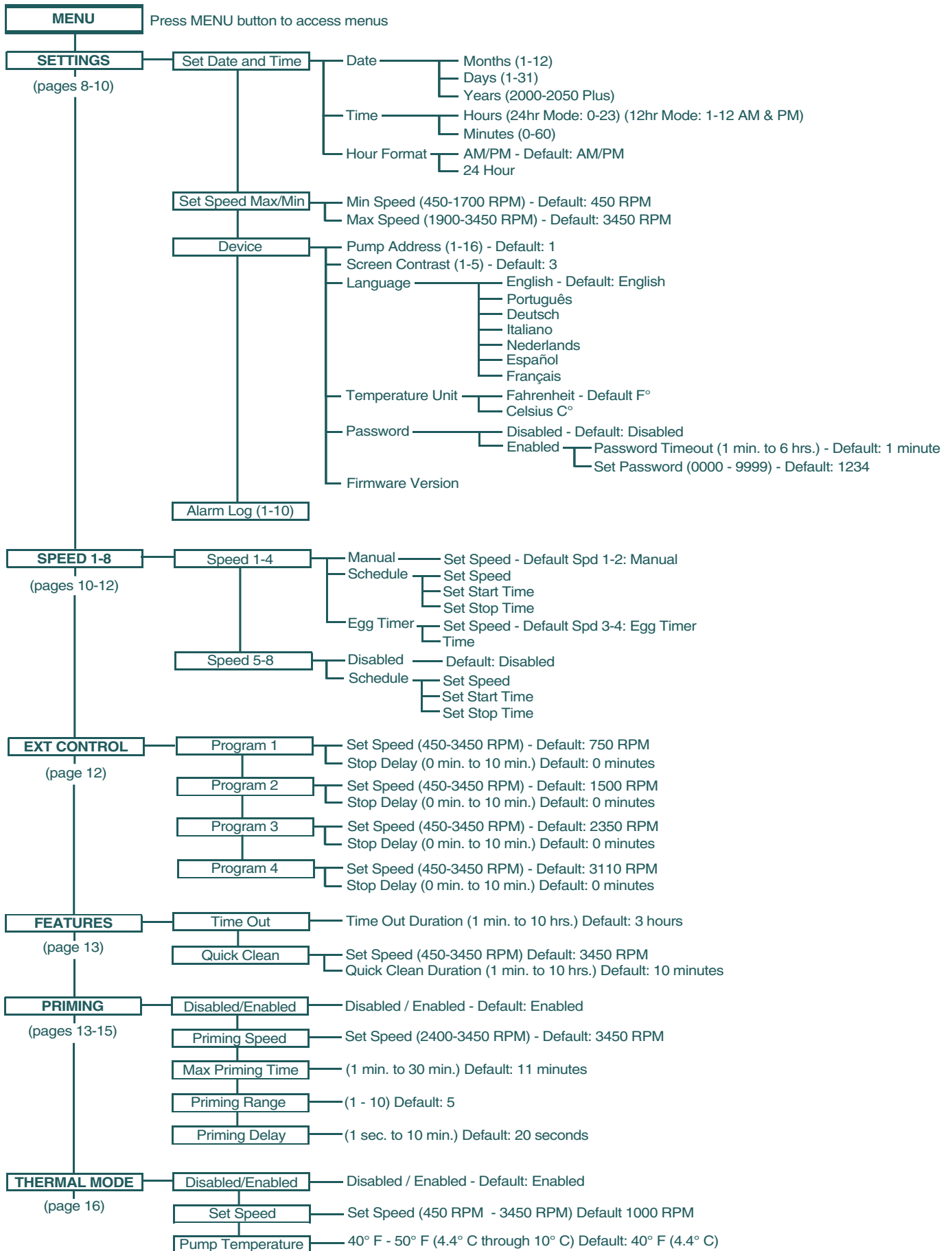



## Set Date and Time

The time controls all scheduled times, functions, and programmed cycles and stores the correct time for up to 96 hours after power is turned off. Reset if the power is off longer than 96 hours.

1. Check that the green power LED is on.
2. Press **Menu**.
3. Press **Select** to select "Settings".
4. Use the **Up** or **Down** arrows to scroll to "Date and Time" and press **Select**.
5. Press **Select** again and use **Up** or **Down** arrows to set the date.
6. Press **Save** to save user input and return to "Date and Time."
7. Use the **Up** or **Down** arrows to scroll to "Time" and press **Select**.
8. Use the **Up** or **Down** arrows to scroll to set the time.  
**Note:** To set AM/PM or a 24 hour clock see the next section "Set AM/PM or 24 Hour Clock."
9. Press **Save** to save. To cancel any changes, press **Back** to exit without saving.
10. Press **Back** to exit.

## Set AM/PM or 24 Hour Clock

To change the time from a 12 hour clock (AM/PM) to a 24 hour clock:

1. Press **Menu**.
2. Press **Select** to select "Settings".
3. Use the **Up** or **Down** arrows to scroll to "Date and Time" and press **Select**.
4. Use the **Up** or **Down** arrows to scroll to "AM/PM" and press **Select**.
5. Use the **Up** or **Down** arrows to scroll to choose between 24 hr. and AM/PM.
6. Press **Save** to save. To cancel any changes, press **Back** to exit without saving.
7. Press **Back** to exit.

## Set Minimum Speed (RPM)

The minimum pump speed can be set from 450 RPM to 1700 RPM. The default setting is 450 RPM.

1. Check that the green power LED is on.
2. Press **Menu**.
3. Press **Select** to select "Settings".
4. Use the **Up** or **Down** arrows to scroll to "Min/Max".
5. Use the **Up** or **Down** arrows to scroll to "Set Min Spd".
6. Press **Select** to change the setting. The cursor will appear in the first number column (ones).

7. Press the **Up** or **Down** arrows to change the minimum speed setting from 450 to 1700 RPM.
8. Press **Save** to save. To cancel, press **Back** to exit edit mode without saving.
9. Press **Back** to exit.

## Set Maximum Speed (RPM)

The maximum speed can be set from 1900 RPM to 3450 RPM (default is 3450). Use this setting to set the maximum running speed of the pump.

1. Check that the green power LED is on.
2. Press **Menu**.
3. Press **Select** to select "Settings".
4. Use the **Up** or **Down** arrows to scroll to "Min/Max".
5. Use the **Up** or **Down** arrows to scroll to "Set Max Spd".
6. Press **Select** to change. The cursor will appear in the first number column (ones).
7. Press **Up** or **Down** arrows to change the maximum speed setting from 1900 to 3450 RPM.
8. Press **Save to save**. Press **Back** to exit. To cancel, press the **Back** to exit without saving.

**Note:** Maximum Speed will limit Priming Speed, except in one case. If the Maximum Speed is set below the lowest available Priming Speed (2350 RPM) then the pump will exceed the Maximum Speed while the priming feature is running. This prevents the pump from having trouble priming if the Maximum Speed is set this low. If this is a problem, priming can be disabled in the Priming Menu (see *Priming* section on page 13).

## Pump Address

The default pump address is #1 and only needs to be changed when there is more than one pump on an automation system. Change the address to allow the automation system to send a command to the correct pump.

Use this setting if your pump is connected via the RS-485 COM port to an IntelliTouch®, EasyTouch®, SunTouch® Control System or IntelliComm® Communication Center. For EasyTouch, SunTouch or IntelliComm systems, the pump only communicates with address #1. The pump address can be set from 1-16. The IntelliTouch system can communicate to only four (1-4) pumps.

**Note:** IntelliFloXF pumps cannot be connected in series with other pumps.

1. Be sure the green power LED is on and the pump is stopped.
2. Press **Menu**.
3. Press **Select** to select "Settings".
4. Use the **Up** or **Down** arrows to scroll to "Device" and press **Select**.



## Pump Menu: Settings

### Pump Address (cont.)

5. Use the **Up** or **Down** arrows to scroll to "Pump Address" and press **Select**.
6. Press **Up** or **Down** arrows to change the address number from 1-16.
7. Press **Save** to save. To cancel any changes, press **Back** to exit without saving.
8. Press **Back** to exit.

### Set Screen Contrast

The default setting for the LCD screen is 3. Screen contrast levels can be adjusted from 0 to 7 units for low or high lighting conditions.

**Note:** Changes to the contrast setting do not update instantaneously. Changes to this setting must be saved before the contrast level changes.

1. Check that the green power LED is on.
2. Press **Menu**.
3. Press **Select** to select "Settings".
4. Use the **Up** or **Down** arrow to scroll to "Device" and press **Select**.
5. Use the **Up** or **Down** arrow to scroll to "Contrast Level."
6. Press **Select**. Screen will show current contrast setting number. Use **Up** or **Down** to change number.
7. Press **Save** to save. To cancel any changes, press **Back** to exit without saving.
8. Press the **Back** button to exit.

### Set Control Panel Language

#### To access the language menu:

1. Check that the green power LED is on.
2. Press **Menu** and press **Select** to select "Settings".
3. Use the **Up** or **Down** arrows and scroll to "Device" and press **Select**.
4. Use the **Up** or **Down** arrows to scroll to "Select Language" and press **Select**.
5. Use the **Up** or **Down** arrows to choose the desired language.
6. Press **Save** to select the control panel language. To cancel any changes, press **Back** to exit without saving.
7. Press **Back** to exit.

### Set Temperature Unit

The pump can be set to either Celsius (°C) or Fahrenheit (°F). The default setting is Fahrenheit (°F).

1. Check that the green power LED is on.
2. Press **Menu**.
3. Press **Select** to select "Settings".
4. Use the **Up** or **Down** arrows to scroll to "Device" menu item. Press **Select**.
5. Use **Up** or **Down** arrows to scroll to "Temperature Units" and press **Select**.
6. Use **Up** or **Down** arrows to choose Celsius (°C) or Fahrenheit (°F).
7. Press **Save** to save. To cancel any changes, press **Back** to exit without saving.
8. Press **Back** to exit.

### Password Protection

The default setting for password protection is disabled. When this feature is enabled, the pump display will prompt for the password before allowing access to the control panel and buttons.

The entered password is any combination of four digits.

- The pump can always be stopped by pressing **Start/Stop**, even when password protection is enabled.
- Password protection cannot be turned back on with **Start/Stop** while running in manual mode.
- Pressing **Start/Stop** when the pump is off will return it back to the Running Cycles Mode and run at the next scheduled run time. If the present time is within the scheduled run time, the pump will run the scheduled speed.
- All functions including programming are disabled in Password Protection Mode.
- Screen will read "Enter Password" if any button other than the **Start/Stop** button is pressed
- Key icon displayed in the upper left side of the screen when Password Protection is on.

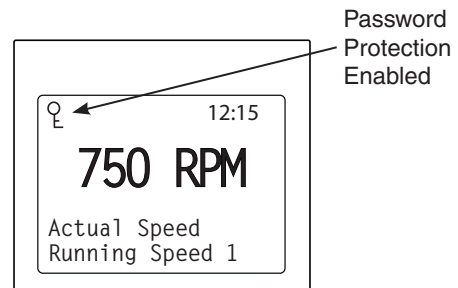



## Setting Password

1. Check that the green power LED is on.
2. Press **Menu**. Press **Select** to select “Settings”.
3. Use the **Up** or **Down** arrow to scroll to “Device”.
4. Press **Select**.
5. Press **Up** or **Down** arrow to scroll to “Password”. The default setting is “Disabled”.
6. Press **Select**.
7. Press **Up** or **Down** arrow to change the setting to “Enabled”. Press **Save** to save.
8. Press the **Down** arrow. “Password Timeout” will be displayed. The factory default time is 1 minute. This means the pump will go into Password Protection mode 1 minute after the last control panel key is pressed.
9. Press **Select** to change time setting from 1 minute to 6 hours and press **Save** to save.
10. Press the **Down** arrow and then press **Select** on “Enter Password” to change the setting.
11. Press the **Left** or **Right** arrows to move cursor and press the **Up** or **Down** arrow to change the password number to desired setting.
12. Press **Save** to save. To cancel any changes, press **Back** to exit without saving.

## Entering Password

1. Press any button (besides a Speed button) to prompt the screen for a password.
2. To enter password, use the **Left** and **Right** arrows to move the cursor and the **Up** and **Down** arrows to scroll through the digit then press **Save** to confirm.



## Pump Operating Modes

The pump can be programmed in three different modes:

**Manual, Schedule, and Egg Timer:** Speeds 1-4 can be programmed in all three modes. Speeds 5-8 can only be programmed in Schedule mode since there are no buttons on the control panel for Speeds 5-8. The default setting for Speeds 5-8 is “Disabled”.

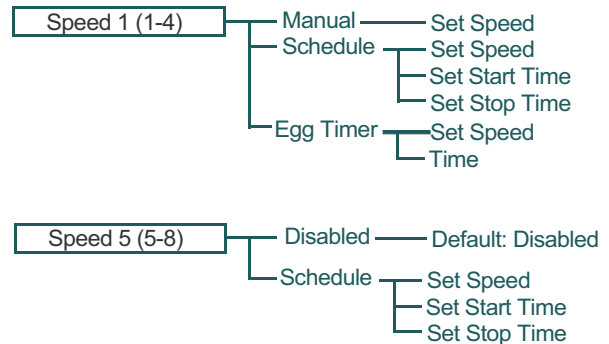

**Speed Menu Tree Options**

## Manual

Assigns a speed to one of the four Speed buttons on the control panel. This mode can only be used for speeds 1-4.

To operate in Manual mode, press one of the four speed buttons and then press the **Start/Stop** button. The pump will run the assigned speed for that speed button.

## Egg Timer

Speeds 1-4 can be programmed to run at a certain speed and for a duration of time once a speed button is pressed.

Speeds 3 and 4 are Egg Timers by default. This prevents the pump from running at a speed higher than half of the maximum speed indefinitely. If you desire a different method of operation, speeds 3 and 4 can be changed to Manual mode in the control menu.

To operate in Egg Timer mode, press a speed button and then press **Start/Stop**. The pump will run that speed for the set amount of time and then turn off.

## Schedule

Program speeds 1-8 start and stop at a specific time during a 24 hour period. Speeds programmed in Schedule mode will override any manually selected speed (speeds set by manually pressing any of the speed buttons on the control panel).



### Set Speeds in Manual Mode (Speeds 1-4 Only)

1. Press **Menu**.
2. Use **Up** or **Down** arrows to scroll to “Speed 1-8”, then press **Select**.
3. Use **Up** or **Down** arrows to find the speed (1-4) you wish to program, then press **Select**.
4. Speeds 1-2 default setting is Manual. Speeds 3-4 default setting is Egg Timer. To set a speed in Manual mode, press the **Down** arrow (“Set Speed” will display) and press **Select** to change. Use the **Up** or **Down** arrow to adjust speed.
5. Press **Save** to save the new speed setting.

### Set Speeds in Egg-Timer Mode (Speeds 1-4 Only)

1. Press **Menu**.
2. Use **Up** or **Down** arrows to scroll to “Speed 1-8”, then press **Select**.
3. Use **Up** or **Down** arrow to find the speed (1-4) you wish to program, then press **Select**.
4. Use the **Up** or **Down** arrows to scroll to “Egg-Timer”, then press **Select**.
5. To set a speed in Egg-Timer mode, press the **Down** arrow (“Set Speed” will display) and press **Select** to change. Use the **Up** or **Down** arrow to adjust speed.
6. Press **Save** to save the new speed setting.
7. Now press the **Down** arrow (“Set Time” will display) and press **Select** to change. Use the **Up** or **Down** arrows to adjust the time.
8. Press **Save** to save the new time setting.

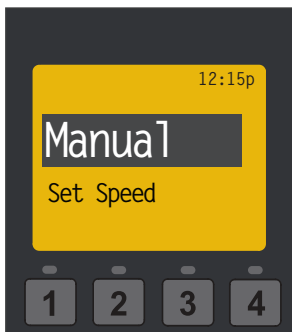

Manual Mode Menu Screen

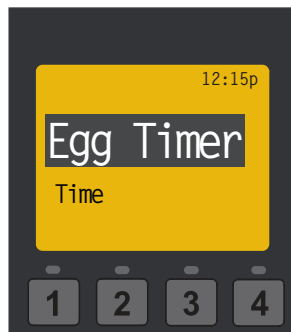

Egg Timer Menu Screen

### Set Speeds 1-8 in Schedule Mode

In Schedule mode, Speeds 1-8 can be programmed to run a certain speed at a certain time of day. To run a scheduled speed, press **Start/Stop**. The screen will display “Running Schedules” when it is ready to run a scheduled speed. If **Start/Stop** is pressed while a scheduled speed is running, the pump will stop running the scheduled speed. The pump will not continue to run the scheduled speed until the **Start/Stop** button is pressed again.

1. Press **Menu**.
2. Use **Up** or **Down** arrows to scroll to “Speed 1-8”, then press **Select**.
3. Use **Up** or **Down** arrows and press **Select** for the speed you wish to set and schedule.
4. Press **Select** (display will be highlighted) and scroll to “Schedule”.
5. Press **Save**.
6. Press **Down** arrow (“Set Speed” will display) and press **Select** to change. Use the **Up** or **Down** arrow to adjust speed.
7. Press **Save** to save the new speed.
8. Press the **Down** arrow again, “Set Start Time” will display. Press **Select** - the cursor will highlight the minute column.
9. Use the **Up** or **Down** arrow to change the time and the **Left** or **Right** arrow to move cursor from minutes to hours.
10. Press **Save** to save the new start time setting.
11. Press **Down** arrow - “Set Stop Time” will display. Press **Select**. Repeat Steps 8-9 to set stop time.
12. Press **Save** to save the new stop time setting.
13. Press **Start/Stop**.

The pump will prime and begin to run the programmed schedule at the specified start time.

When running in Schedule or Egg Timer mode, the countdown time (T 00:01) showing the hours and minutes remaining is displayed.



## Set Speeds 1-8 in Schedule Mode (cont.)

### Programming Schedule for Constant Run

A speed cannot be programmed with the same start and stop times. To run a speed without stopping, set the Start time one minute after the stop time.

**Example:** A single speed will run non stop if programmed with a Start Time of 8:00 AM and a Stop time of 7:59 AM.



**Note:** The pump will not run the scheduled speeds until the **Start/Stop** button is pressed (LED on) to place the pump in Schedule mode.

**Note:** When two speeds are scheduled during the same run time the pump will run the higher RPM Speed regardless of Speed # in use.

**Note:** The most recent command, Manual or Schedule, takes priority regardless of speed number RPM.



## External Control

This function is for programming speeds that will run when the IntelliComm® Communication Center sends it a command. For example, Terminal 3 and 4 in the IntelliComm system will correspond to External Control Program #1. (5 and 6 to Ext Ctrl #2).

The Stop Delay feature allows the user to program the pump to run a Program Speed after the External Control has been deactivated. This feature can be used to provide a cooling down period for the pump after a trigger signal from an installed heater has been deactivated. Each individual Program Speed can have a Stop Delay of 1 to 10 minutes programmed.

Use the External Control feature to program the IntelliComm system power center.

### To access the External Control menu:

1. Check that the green power LED is on.
2. Press the **Menu** button.
3. Use **Up** or **Down** arrow to scroll to “Ext. Ctrl.”.
4. Press **Select**. “Program 1” is displayed.
5. Press **Select**. “750 RPM” is displayed.
6. Press **Select**. The “RPM” number will highlight.
7. Press **Up** or **Down** arrow to change the RPM setting.
8. Press **Save** to save the setting.
 

**Note:** To cancel any changes, press the **Back** button to exit without saving.
9. If you do not wish to program a Stop Delay, continue to step 13. If you do wish to program a Stop delay press **Up** or **Down** arrow to scroll to “Stop Delay”.
10. Press **Select** to set Stop Delay.
11. Press **Up** or **Down** arrows to change the Stop Delay setting. Stop Delay can be set from 0 minutes (disabled) to 10 minutes.
12. Press **Save** to save the setting.
 

**Note:** To cancel any changes, press the **Back** button to exit without saving.
13. Press **Back** to return to set Program 2.
14. Use **Up** or **Down** arrow to scroll to “Program 2”.
15. Repeat Steps 5 through 13 to set Program 2, 3, and 4.



## MENU

### FEATURES — Pump Menu: Features

#### Time Out

The Time Out feature keeps the pump from running at its programmed speeds for a set duration adjustable in the menu. The Time Out feature is displayed in hours and minutes (Hrs:Mins).

Once Time Out is finished, the pump will return to its previous mode of operation, the Start/Stop LED will be lit and ready to turn on at the next scheduled run time.

#### To access the Time Out menu:

1. Check that the green power LED is on.
2. Press **Menu**.
3. Use **Up** or **Down** arrows to scroll to “Features”, then press **Select**.
4. Press **Select** to choose “Timeout”.
5. Then press **Select** again to choose “Timeout Duration”.
6. Press **Select** to change the time. The cursor will highlight the minutes column.
7. Press the **Left** arrow to move cursor to the hours column. Time out can be set from 1 minute to 10 hours.
8. Press **Save** to save the setting.
 

**Note:** To cancel any changes, press **Back** to exit without saving.
9. Press **Back** to exit the menu.

#### Quick Clean

**Note: Quick Clean is the only high-speed override feature of the pump.**

This feature can be used to increase the pump speed for vacuuming, cleaning, adding chemicals, after a storm for extra skimming capability.

Press the **Quick Clean** button (LED on) and then **Start/Stop** to start. When the Quick Clean cycle is over, the pump will resume regular schedules and be in “Running Schedule” mode.

#### To access the Quick Clean menu:

1. Check that the green power LED is on and the pump is stopped.
2. Press **Menu**.
3. Use **Up** or **Down** arrows to scroll to “Features”, then press **Select**.
4. Press the **Down** arrow and press **Select** for “Quick Clean”.
5. Press **Select** to choose “Set Speed”.
6. Press **Select** to highlight the “RPM” first (ones) column and change the speed.
7. Use **Up** or **Down** arrows to change the speed.

8. Press **Save** to save the speed.
9. Press the **Down** arrow again, and press **Select** for “Time Duration”.
10. Press **Select** to change the time. The cursor will highlight the minutes column.
11. Use **Up** or **Down** arrows to change the time from 1 minute to 10 hours.
12. Press **Save** to save the time.
13. Press **Back** to exit the menu.

## MENU

### PRIMING — Pump Menu: Priming

The default setting for Priming is ENABLED. This setting allows the pump to automatically detect if it is primed for startup.

The priming feature increases the pump speed to 1800 RPM and pauses for 3 seconds. If there is sufficient water flow in the pump basket, the pump will go out of priming mode and run its commanded speed.

If the water flow is not sufficient, the pump speed will increase to the “Max Speed” setting and remain for the priming delay time (default 20 seconds). If there is sufficient water flow in the pump basket at this time, it will exit priming mode and transition to the commanded speed.

If there is still insufficient flow in the pump basket, as determined by the Priming Range setting, the pump will try to prime at the “Priming Speed” for the amount of time set in the “Maximum Priming Time” menu, unless the set “Maximum Speed” is lower than the set “Priming Speed”. Once the pump achieves prime, it will resume normal operation after the preset priming delay.

**Note:** It is possible to set “Maximum Speed” too low for the pump to properly prime. Maximum Speed will limit Priming Speed, except in one case. If the Maximum Speed is set below the lowest available Priming Speed (2350 RPM) then the pump will exceed the Maximum Speed while the priming feature is running. This prevents the pump from having trouble priming if the Maximum Speed is set this low. If this is a problem, priming can be disabled in the Priming Menu.

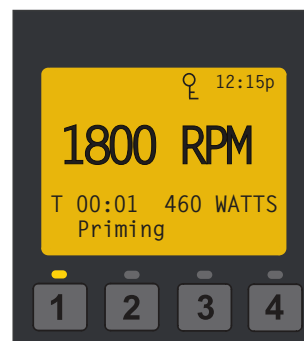

Display during priming



## Priming Features

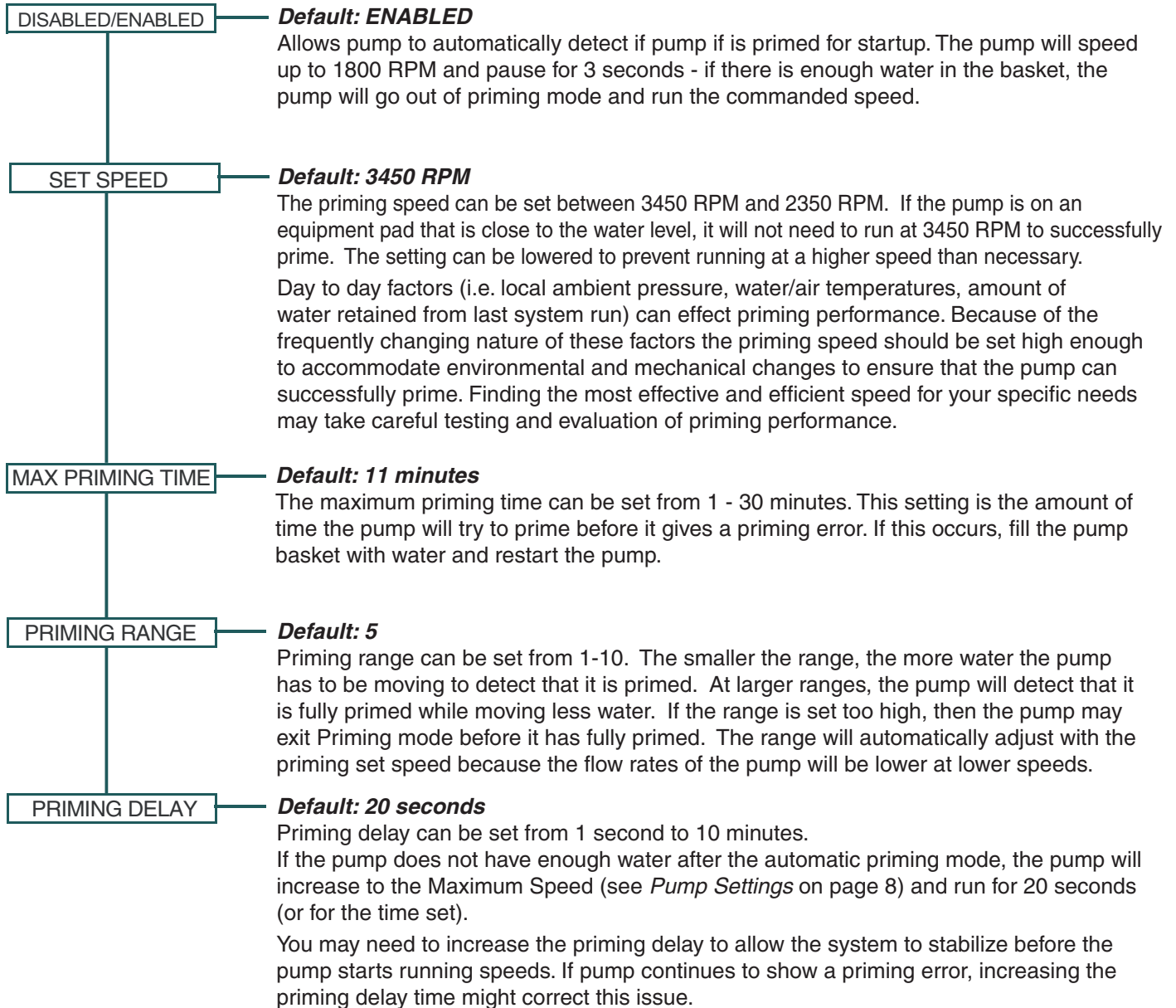

MENU

PRIMING

## Pump Menu: Priming

### Setting Priming Features

**Note:** Priming features are only accessible if priming is “Enabled”.

1. Press **Menu**.
2. Use **Down** arrow to scroll to “Priming” and press **Select**.
3. The factory default is set to priming “Enabled”. To disable, press **Select**.
4. Press **Save** if you have changed the setting - this will save the selection.
5. Press the **Down** arrow - the screen will read “Max Priming Time”.
6. To change from factory default, press **Select**. The cursor will highlight.
7. Use the **Up** or **Down** arrows to change the time from 1 minute to 30 minutes.
8. Press **Save** to save.
9. Press the **Down** arrow - the screen will read “Priming Range”. Default is “5”.
10. Press **Select** to change the priming range. The cursor will highlight the number.
11. Use the **Up** or **Down** arrows to change from 1 to 10. Increasing the number allows the drive to detect prime with less water flow.
12. Press **Save** to save.
13. Press the **Down** arrow - the screen will read “Priming Delay”. Default is 20 seconds.
14. Press **Select** to change the priming delay time.
15. Use the **Up** or **Down** arrows to change from 1 second to 10 minutes.

**CAUTION:** Increasing the time causes the pump to stay in the priming mode longer.

16. Press **Save** to save the setting.

17. Press **Back** to exit.

### Disabling Priming with an Automation System

When the pump is connected to an automation control system, (IntelliTouch®, EasyTouch® or SunTouch® Control Systems), **the priming feature on the pump cannot be disabled by the external automation control system only. It must also be disabled on the pump itself.**

If priming is enabled on start up, the pump responds to its internal settings *before* responding to commands from an automation control system.

If the pump is connected to an automation control system and priming is not desired, **disable the priming feature on both the pump and the automation control system.**

#### To disable priming with an automation system:

1. Disable the priming feature on the automation control system at the load center or using an IntelliTouch or EasyTouch system remote. (Refer to the automation control system user’s guide for additional information).
2. Temporarily disconnect the RS-485 communication cable.
3. Open the lid to the control panel to disable priming on the pump. Press **Menu**, use the **Arrow** buttons to scroll and select “Priming”, then select “Disabled” (the factory default is set to “Enabled”). Press **Save** to save the setting. Press **Back** to exit the menu.
4. Once priming is disabled, reinstall the RS-485 communication cable.

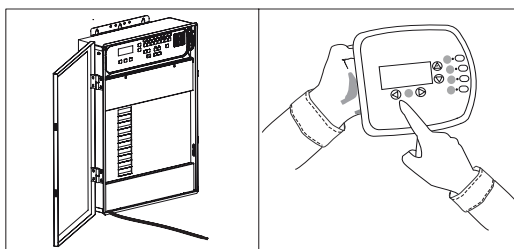

1. Disable priming on automation control system.

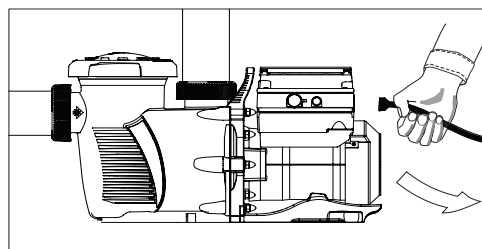

2. Disconnect the RS-485 communication cable.

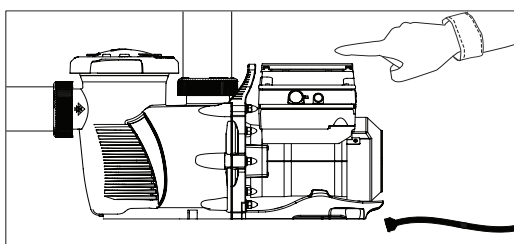

3. Disable priming on pump.

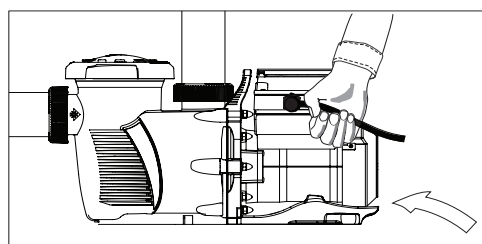

4. Reinstall the RS-485 communication cable.



**Pump Menu: Thermal Mode**

The sensor for Thermal Mode is in the drive, on top of the motor. This feature allows you to set a speed (450 RPM - 3450 RPM) that runs when the pump goes into Thermal Mode. The temperature level that you wish Thermal Mode to start can also be set.

**IMPORTANT NOTE:** This feature is for protection of the pump. Do not depend on the Thermal Mode feature for freeze protection of the pool. Certain situations could cause the pump to sense a different temperature than actual air temperature.

Your automation systems air temperature sensor should be used to sense actual temperature. For example, if the pump is located indoors, the temperature of the room does not indicate the outdoor temperature. The pump does not sense the water temperature.

**To access the Thermal Mode menu:**

1. Check that the green power LED is on.
2. Press **Menu**.
3. Use the **Down** arrow to scroll to “Thermal Mode” and press **Select**.
4. The factory default for Thermal Mode is “Enabled”. To disable Thermal Mode, press **Select** to highlight “Enabled”.
5. Press the **Up** arrow - “Disabled” is displayed.
6. Press **Save** to save.



**Setting the Thermal Mode Pump Speed**

**To Set Thermal Mode Speed and Pump Temperature:**

**Note:** Thermal Mode features are only accessible if Thermal Mode is “Enabled”.

1. With “Thermal Mode” displayed on the screen, press the **Down** arrow - “Set Speed” is displayed. The factory default is 1000 RPM.
2. Press **Select** to change the speed. The cursor will highlight the first column (ones).
3. Use the **Up** or **Down** arrows to set speed (450 - 3450 RPM).
4. Press **Save** to save the speed.
5. Press the **Down** arrow to Pump Temperature. This setting determines when Thermal Mode is activated. Default setting is 40°F (4.4°C)
6. Press **Select** to change the setting. The cursor will highlight the first column. Can be set 40°F to 50°F (4.4°C - 10°C).
7. Press **Save** to save the temperature setting.

**Note:** To cancel any changes, press **Back** to exit without saving.

8. Press **Back** to exit.

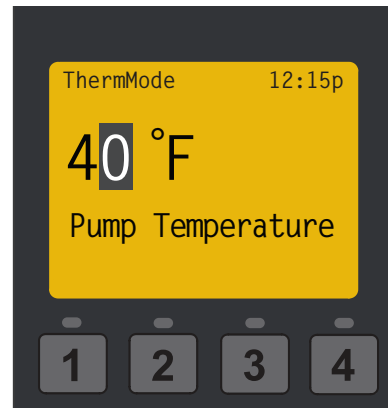

**Setting the Thermal Mode Pump Temperature**

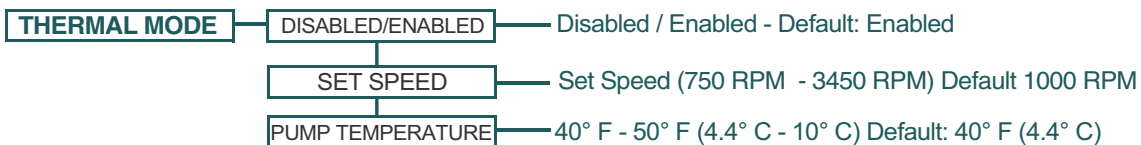

**Thermal Mode Menu Options**

# CONNECTING TO AN AUTOMATION SYSTEM

## External Control with IntelliComm® Communication Center

Use the RS-485 communications cable to remotely control the pump from an IntelliComm communication center. The IntelliComm system provides four pairs of input terminal connections. These inputs are actuated by either 15 - 240 VAC or 15 - 100 VDC. Use the device inputs, to control the programmed pump speeds.

**Note:** For the pump to accept commands from the IntelliComm system, the pump must be in the “Running Schedules” mode (LED above Start/Stop button is on). If more than one input is active, the highest number will be communicated to the pump. The IntelliComm system will always communicate to pump using ADDRESS #1.

### Program Number Priority

If programs 1 and 2 are activated, program 2 will run, regardless of the assigned speed (RPM). The higher program number will always take priority.

*Refer back to page 12 for instructions for setting up Programs in the External Control menu.*

External Control is for programming speeds that will run when the IntelliComm communication center controller sends it a command.

For example, Terminal 3 and 4 in IntelliComm system will correspond to External Control Program #1. (5 and 6 to Ext Ctrl #2). Use the External Control feature to program the IntelliComm communication center.

## Wiring Terminal Descriptions for IntelliComm Communication Center

Terminal Number	Terminal Name	Voltage	Max. Current	Phase Type	Frequency
1-2	Power Supply	100 - 240 VAC	100 mA	1 Input	50/60 Hz
3-4	Program 1	15 - 240 VAC or 15 - 100 VDC	1 mA	1 Input	50/60 Hz
5-6	Program 2	15 - 240 VAC or 15 - 100 VDC	1 mA	1 Input	50/60 Hz
7-8	Program 3	15 - 240 VAC or 15 - 100 VDC	1 mA	1 Input	50/60 Hz
9-10	Program 4	15 - 240 VAC or 15 - 100 VDC	1 mA	1 Input	50/60 Hz
11 12	RS-485 + Data: Yellow - Data: Green	-5 to +5 VDC	5 mA	1 Output	N/A
	Ground				

## Connecting to EasyTouch® and IntelliTouch® Control Systems

The pump can be controlled by an EasyTouch or IntelliTouch system via the RS-485 communication cable. The EasyTouch and/or IntelliTouch control system starts, stops and controls the speed of the pump.

EasyTouch and/or IntelliTouch systems rewrite the pump memory when a command is given. This can take several seconds and can cause a delay until the pump physically responds.

The pump control panel is disabled when communicating with an EasyTouch and/or IntelliTouch system. **The EasyTouch and/or IntelliTouch system will not start communicating with the pump until the pump is assigned to a circuit.** The default pump address is “1” (only address for EasyTouch system).



**IntelliComm Communication Center**

*See page 8 for details about how to check and or set the pump address. For more information, refer to the IntelliTouch (P/N 520100) or EasyTouch Automation System User’s Guide (P/N 520584).*

*Installation and User’s Guides are available at: [www.pentair.com](http://www.pentair.com).*

**To connect the pump communication cable to EasyTouch® or IntelliTouch® Control System load center:**

1. Switch the main power off to the load center.
2. Unlatch the two enclosure door spring latch, and open the door.
3. Remove the two retaining screws securing the high voltage cover panel, and remove it from the enclosure.
4. Loosen the two access screws securing the control panel.
5. Lower down the hinged control panel to access the EasyTouch or IntelliTouch control system circuit board.
6. Route the communication cable into the plastic grommet (located on the lower left side of the load center), up through the low voltage raceway to the EasyTouch or IntelliTouch system circuit board.
7. Strip back the cable conductors 6 mm (1/4"). Insert the two wires into the COM port screw terminals on the EasyTouch and/or IntelliTouch system circuit board. Secure the wires with the screws.
8. **EasyTouch COM port (J20):** Connect the GREEN (#2) and YELLOW (#3) wires to the COM port screw terminals (#2 and #3). Be sure to match the color coding of the wires; YELLOW to YELLOW and GREEN to GREEN. The Red wire is not connected. Secure the wires with the screws.

**IntelliTouch COM port (J7/8):** Connect the GREEN (#2) and YELLOW (#3) wires to the COM port (J20) screw terminals (#2 and #3). Be sure to match the color coding of the wires; YELLOW to YELLOW and GREEN to GREEN. The Red wire is not connected. Secure the wires with the screws.

**Note:** Multiple wires may be inserted into a single screw terminal.

9. Close the control panel into its original position and secure it with the two screws.
10. Install the high voltage cover panel and secure it with the two retaining screws.
11. Close the load center front door. Fasten the spring latch.
12. Switch the power on to the load center.

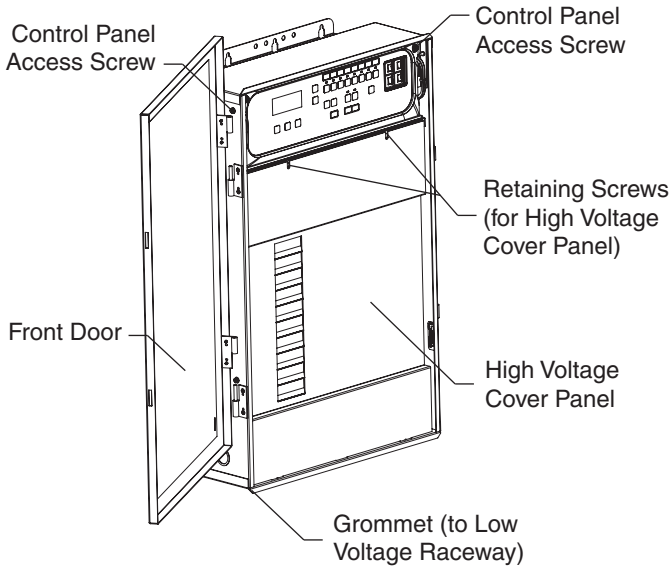

**EasyTouch and/or IntelliTouch Control System Load Center**

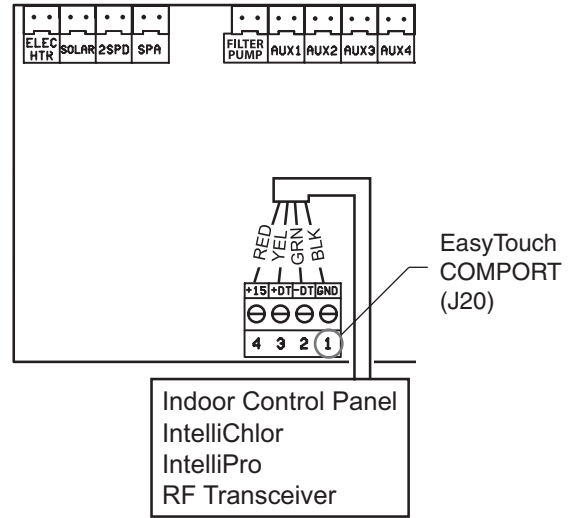

**EasyTouch Control System Circuit Board**

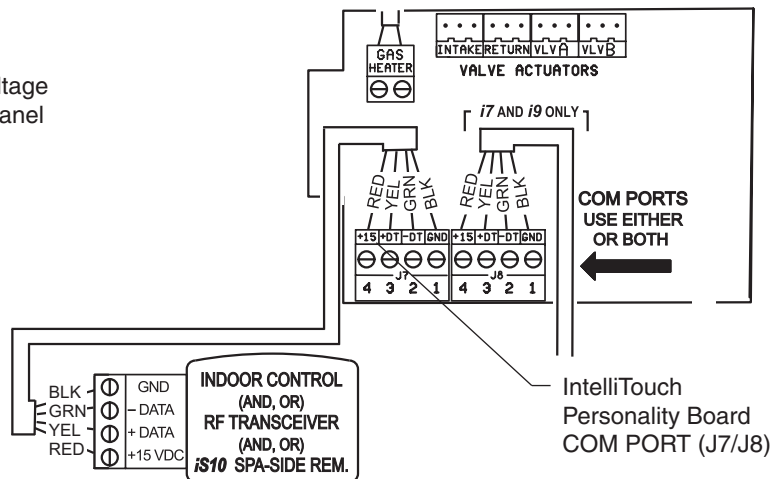

**IntelliTouch Control System Circuit Board**

## Connecting the Pump to a SunTouch® Control System

The pump can be controlled by a SunTouch system via the RS-485 communication cable.

### To connect the pump RS-485 communication cable to the SunTouch control system circuit board:

1. Unlatch the front door of the SunTouch system power center and open the door.
2. Loosen the retaining screw on front panel. Open the hinged front panel to access the electronics compartment.
3. Route the two conductor cable up through the power center grommet opening located on the left side, and up through the low voltage raceway to the motherboard.



**WARNING** Switch OFF main system power to the SunTouch system power center before making any connections.

4. Strip back the cable conductors 6 mm (1/4"). Insert the wires into the screw terminals (provided). Secure the wires with the screws. Be sure to match the color coding of the wires; **YELLOW to YELLOW** and **GREEN to GREEN**.
5. Insert the connector on the COMPORT (J11) screw terminal on the SunTouch system circuit board.
6. Close the control panel and secure it with the retaining screw.
7. Close the front door. Fasten the spring latch.

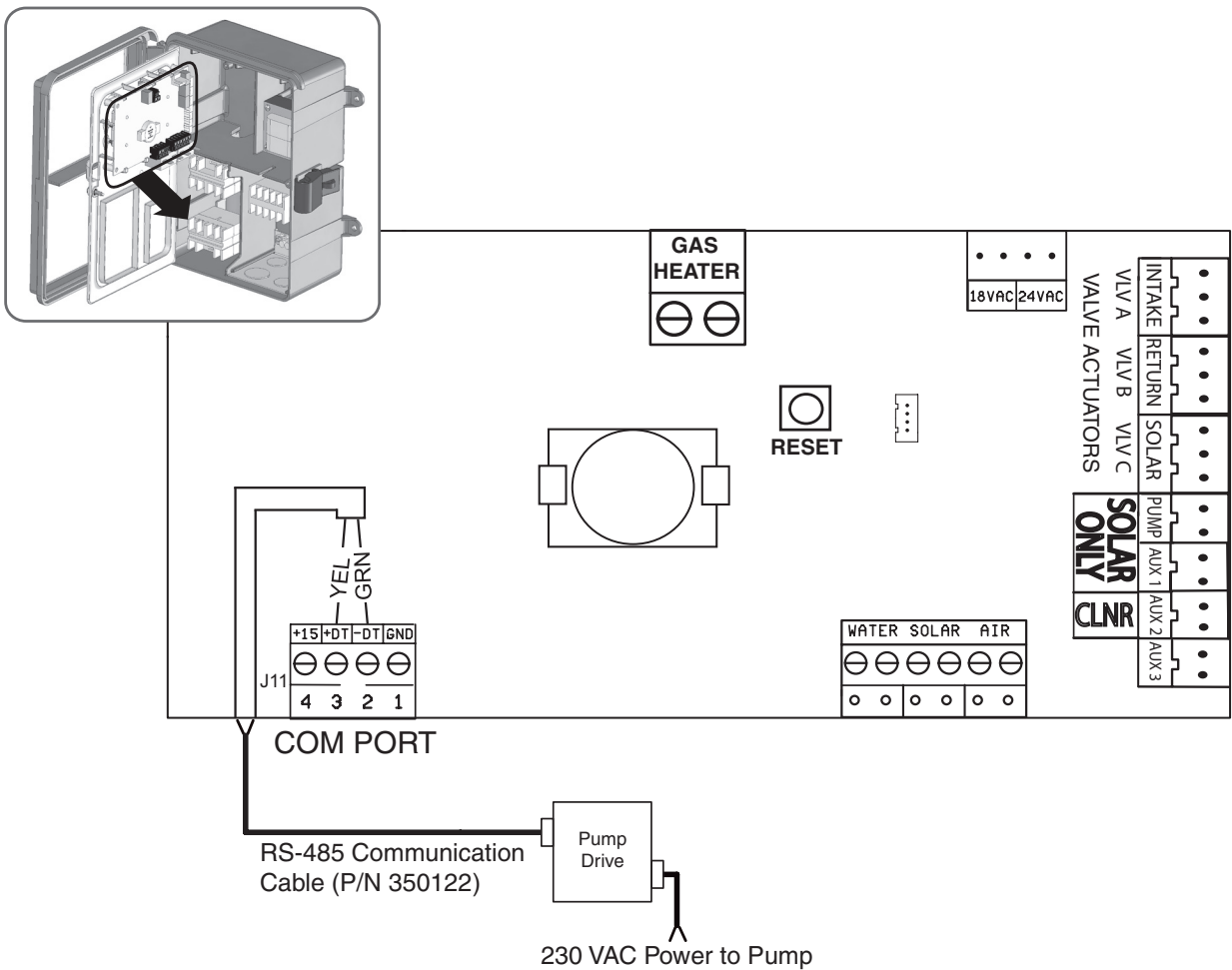

**SunTouch Control System Circuit Board**

## MAINTENANCE

**⚠ WARNING** DO NOT open the strainer pot if pump fails to prime or if pump has been operating without water in the strainer pot. Pumps operated in these circumstances may experience a build up of vapor pressure and may contain scalding hot water. Opening the pump may cause serious personal injury. In order to avoid the possibility of personal injury, make sure the suction and discharge valves are open and strainer pot temperature is cool to touch, then open with extreme caution.

**⚠ WARNING** Always disconnect power to the pump at the circuit breaker and disconnect the digital input cable before servicing the pump. Failure to do so could result in death or serious injury to service people, users or others due to electric shock. Read all servicing instructions before working on the pump.

**⚠ CAUTION** To prevent damage to the pump and for proper operation of the system, clean pump strainer and skimmer baskets regularly.

### Cleaning the Pump Strainer Basket

The strainer pot is located at the front of the pump and houses the pump strainer basket.

The strainer basket can be viewed through the strainer pot lid and should be visually inspected at least once a week. Regularly emptying and cleaning the strainer basket will lead to higher filter and heater efficiency and prevent unnecessary stress on the pump motor.

#### TO CLEAN THE STRAINER BASKET:

1. Press **Start/Stop** to stop the pump and shut off all electrical power to the pump at the circuit breaker.
2. Open the filter air relief valve and relieve all pressure from the filtration system.
3. Turn the strainer pot lid counter-clockwise and remove it from the pump.
4. Remove debris and rinse out the basket. Replace the basket if it is cracked or damaged.
5. Place the basket into the strainer pot. Ensure the notch in the bottom of the basket is aligned with the rib in the bottom of the strainer pot.
6. Fill the strainer pot with water up to the inlet port.
7. Clean the lid O-ring and sealing surface of the strainer pot.

**Note:** It is important to keep the lid O-ring clean and well lubricated.

8. Reinstall the lid by placing it onto the strainer pot and tightening clockwise until the lid handles are horizontal.

**Note:** Ensure the lid O-ring is properly placed and is not being pinched between the lid and strainer pot.

**Note:** Ensure that the side of the lid marked "Front" is positioned at the front of the pump.

9. Open the filter air relief valve and stand clear of the filter.
10. Reestablish electrical power to the pump at the circuit breaker and start the pump.
11. When a steady stream of water flows from the filter air relief valve, close the valve.

**⚠ WARNING** THIS SYSTEM OPERATES UNDER HIGH PRESSURE. When any part of the circulating system is serviced, air can enter the system and become pressurized. Pressurized air can cause the lid to separate which can result in serious injury, death, or property damage. To avoid this potential hazard, follow above instructions.



### Winterizing

You are responsible for determining when freezing conditions may occur. If freezing conditions are expected, take the following steps to reduce the risk of freeze damage. **Freeze damage is not covered under warranty.**

In mild climate areas, when temporary freezing conditions may occur, run your filtering equipment all night to prevent freezing.

#### TO PREVENT FREEZE DAMAGE:

1. Press the **Start/Stop** button to stop the pump.
2. Disconnect all power to the pump at the circuit breaker.
3. Relieve all pressure from the filtration system at the filter air relief valve.
4. Remove both drain plugs from the bottom of the strainer pot and drain the pump. Store the plugs in the strainer basket.
5. Cover the motor to protect it from severe rain, snow and ice.

**Note:** Do not wrap motor with plastic or other air tight materials during winter storage. Never cover the motor when operating or expecting operation.

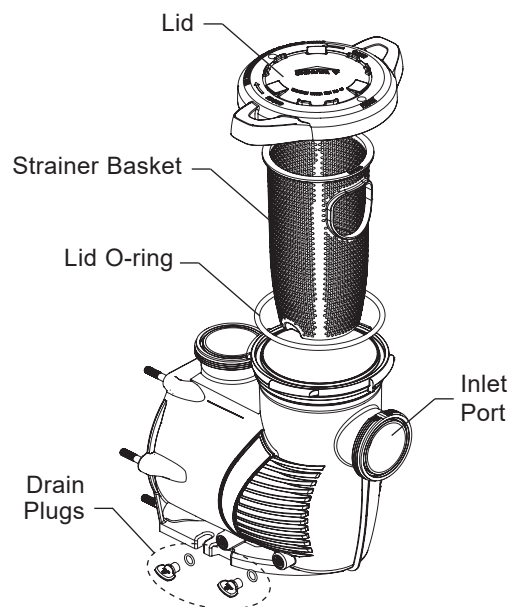

**Strainer Pot Assembly**



**⚠ WARNING** Always disconnect power to the pump at the circuit breaker and disconnect the communication cable before servicing the pump. Failure to do so could result in death or serious injury to service people, users or others due to electric shock. Read all servicing instructions before working on the pump.

**⚠ WARNING** **DO NOT** open the strainer pot if pump fails to prime or if pump has been operating without water in the strainer pot. Pumps operated in these circumstances may experience a build up of vapor pressure and may contain scalding hot water. Opening the pump may cause serious personal injury. In order to avoid the possibility of personal injury, be sure the suction and discharge valves are open and strainer pot temperature is cool to touch, then open with extreme caution.

**⚠ CAUTION** Be sure not to scratch or mar the polished shaft seal faces; seal will leak if faces are damaged. The polished and lapped faces of the seal could be damaged if not handled with care.

## Motor and Drive Care

### Protect from heat

1. Shade the motor from the sun.
2. Any enclosure must be well ventilated to prevent overheating.
3. Provide ample cross ventilation.
4. Provide a minimum clearance of 3 in. (7.6 cm) behind the motor fan for proper circulation.

### Protect against dirt

1. Protect from any foreign matter.
2. Do not store (or spill) chemicals on or near the motor.
3. Avoid sweeping or stirring up dust near the motor while it is operating.
4. If a motor has been damaged by dirt it may void the motor warranty.

### Protect against moisture

1. Protect from continuous splashing or continuous sprayed water.
2. Protect from extreme weather such as flooding.
3. If motor internals have become wet - let it dry before operating. Do not allow the pump to operate if it has been flooded.
4. If a motor has been damaged by water it may void the motor warranty.
5. Close the keypad cover after every use.

## Pump Disassembly

### TOOLS REQUIRED:

- 3/8-inch socket wrench
- 9/16-inch open-end wrench
- 9/64-inch hex key wrench
- 1/4-inch hex key wrench
- Phillips-head and flat-head screwdriver
- Torque wrench

### TO DISASSEMBLE THE PUMP:

1. Press **Start/Stop** to stop the pump and disconnect all power to the pump at the circuit breaker.
2. Disconnect any digital inputs or communication cables from the pump.
3. Close all valves in suction and discharge pipes and relieve all pressure from the system.
4. Remove both Drain Plugs from the bottom of the Strainer Pot.

### Pump Disassembly (cont.)

5. Remove the four Phillips-head Drive Cover Screws from the outer corners of the keypad.
6. Disconnect the Drive Cover from the Drive and set it aside.
7. Remove the three Phillips-head Drive-to-Motor Screws, located inside the drive.
8. Lift the drive from the motor and set it aside.
9. Using a 9/16-inch open end wrench remove the six nuts and washers securing the Strainer Pot to the motor assembly.
10. Gently pull the two pump halves apart.
11. Using a 9/64-inch hex key wrench, remove the three Diffuser Screws securing the diffuser to the Seal Plate and remove the Diffuser.
12. Hold the impeller in place by hand. Using a 3/8-inch socket wrench, remove the impeller screw and washer.

**Note:** The screw is a left-handed thread and loosens in a clockwise direction.

**Note:** If the impeller screw has a plastic head a 3/4-inch socket is required. This screw will also include an O-ring instead of a washer.

**⚠ CAUTION** The impeller may have sharp edges that could potentially cut or scratch the user's hands. Safety gloves are recommended when holding the impeller during disassembly and reassembly.

13. Using a 1/4-inch hex key wrench, hold the motor shaft in place at the back of the motor. Turn the impeller counter-clockwise and remove it from the shaft.
14. Using a 9/16-inch wrench, remove the four motor nuts and washers securing the seal plate to the motor.
15. If replacing the shaft seal, continue to *Shaft Seal Replacement* on the next page. Otherwise, continue to *Pump Reassembly* when necessary.

## Shaft Seal Replacement

The Shaft Seal consists of two halves, a rotating spring seal and a fixed ceramic seal. The shaft seal may occasionally become damaged and require replacement.

**CAUTION** Scratching, marring or otherwise damaging the polished shaft seal faces will cause the seal to leak. Always handle the shaft seal faces with care and clean them thoroughly before reassembling the pump.

1. Ensure you have completed all pump disassembly instructions on the previous page.
2. Remove the old Spring Seal from the impeller shaft with a pair of pliers.
 

**Note:** When removing the spring seal the inner sleeve of the seal may stick to the shaft. Ensure it is removed before installing the new spring seal.
3. Place the seal plate face down on a flat surface and tap out the old ceramic seal with a flat-blade screwdriver.
4. Flip the seal plate over and thoroughly clean the seal cavity.
5. Lightly lubricate the outside rubber surface of the new ceramic seal with water.
6. **With the White Ceramic Face upwards**, firmly press the new Ceramic Seal into the seal plate cavity with your thumbs.
7. Thoroughly clean the seal face with a clean cloth.
8. Using a 9/16" wrench, secure the seal plate to the motor with the four motor bolts. Tighten to 75-80 in-lbs. (86-92 kg/cm).
9. **With the Flat Face towards the impeller**, slide the new spring seal onto the impeller shaft.
10. Thoroughly clean the seal face with a clean cloth
11. Hold the motor shaft in place at the rear of the motor and hand tighten the impeller clockwise onto the motor shaft.
12. Continue reassembling the pump according to the instructions given in *Pump Reassembly*.

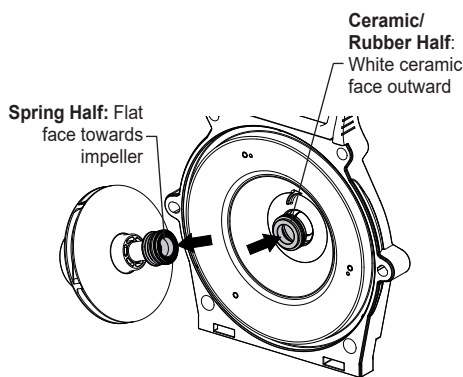

**Shaft Seal Replacement**

## Pump Reassembly

1. Using a 9/16" wrench, secure the seal plate to the motor with the four motor nuts. Tighten to 75-80 in-lbs. (86-92 kg/cm).
2. Hold the motor shaft in place at the rear of the motor and hand tighten the impeller clockwise onto the motor shaft.
3. Continue to hold the motor shaft in place and reinstall the impeller screw and washer.
 

**Note:** The impeller screw is reverse thread and tightens counter-clockwise.

**Note:** Some pumps contain an O-ring instead of a washer. Before reassembling, inspect the O-ring for damage and replace if needed.
4. Secure the diffuser onto the seal plate with the three diffuser screws. Ensure the plastic pins and holding screw inserts are aligned (see "TOP" indicator).
 

**Note:** Ensure that the seal plate and diffuser O-rings are clean and free of debris.
5. Using a 9/16-inch open-end wrench, secure the motor assembly to the strainer pot with the six seal plate nuts and washers. Tighten to a maximum of 100 in-lbs (115 kg/cm).
6. Reinstall the drive onto the motor.
7. Reinstall both drain plugs and fill the pump with water.
8. Prime the system. See page 4 for priming instructions.

**CAUTION** The impeller may have sharp edges that could potentially cut or scratch the user's hands. Safety gloves are recommended when holding the impeller during disassembly and reassembly.

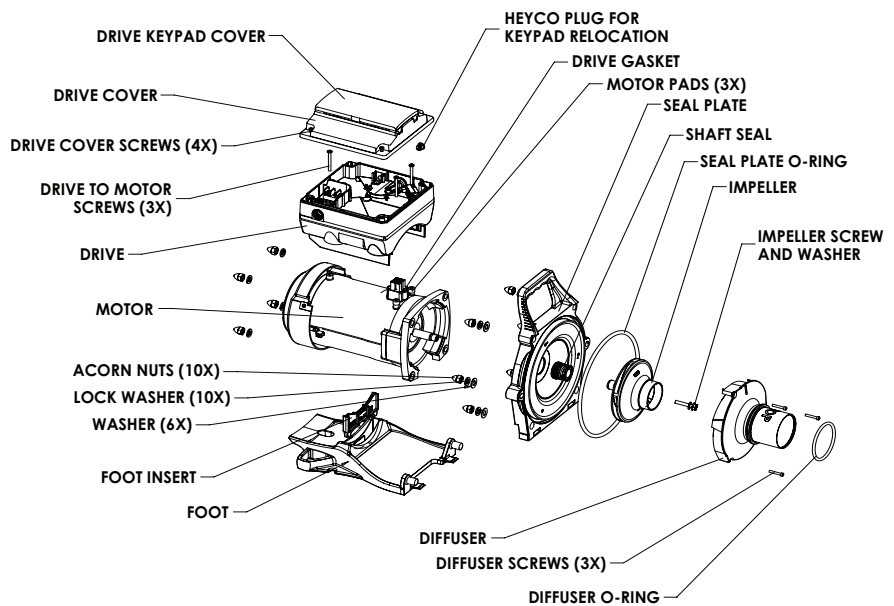

**Motor Assembly Breakdown**

## Drive Assembly Removal and Installation

**WARNING** **FIRE and BURN HAZARD** - The pump motor may run at a high temperatures. To reduce the risk of fire, do not allow leaves, debris, or foreign matter to collect around the pump motor. To avoid burns when handling the motor, shut off the motor and allow it to cool for 20 minutes before servicing. The pump provides an automatic internal cutoff switch to protect the motor from heat damage during operation.

**CAUTION** To avoid electrical hazard, do not remove the four tamper proof screws from the motor assembly.

### To remove the drive and control panel from the motor assembly:

1. Press **Start/Stop** to stop the pump and disconnect all power to the pump at the circuit breaker.
2. Disconnect any digital inputs or communication cables from the pump.
3. Remove the four Phillips-head Drive Cover Screws from the outer corners of the keypad.
4. Unplug the keypad from the drive and set it to the side.
5. Remove the three Phillips-head Drive-to-Motor Screws, located inside the drive.
6. Lift the drive from the motor and set aside.

**Note:** Be careful not to remove the gasket between the drive and motor. It is critical in keeping moisture out of the drive and motor. Replace the gasket if damaged. Do not reassemble with a damaged or missing gasket.

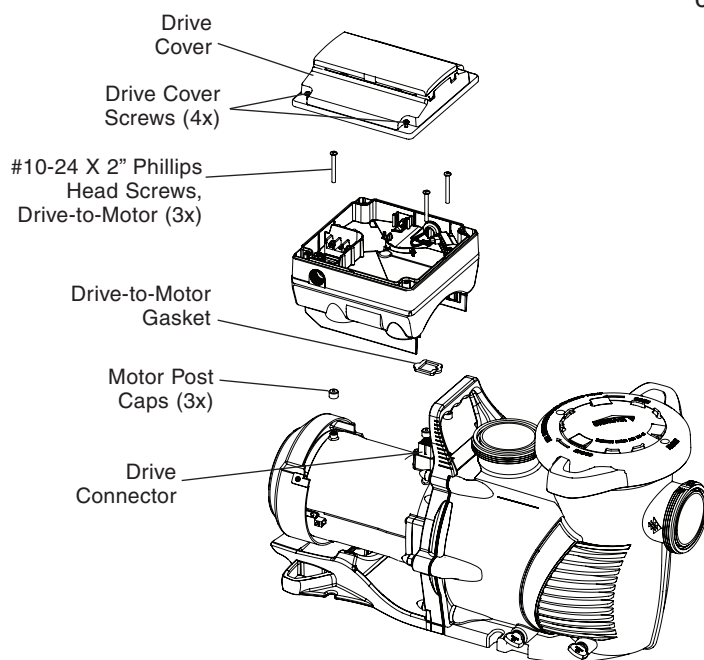

**Drive Assembly and Removal**

### To install the drive assembly onto the motor assembly:

1. Ensure all power to the pump and any automation controls are turned off at the circuit breakers.
2. Ensure that the gasket between the drive and motor is in place. It is critical in keeping moisture out of the drive and motor. Replace the gasket if damaged. Do not reassemble with a damaged or missing gasket.
3. Verify that the three orange motor post caps are in position before placing the drive on the motor assembly.
4. Align the drive assembly with the motor adapter and seat the drive on the motor assembly.
5. Secure and tighten the drive assembly with the three Phillips-head Drive-to-Motor Screws.
6. Plug the keypad back into the drive.
7. Place the keypad in the desired orientation on the drive and reinstall the four Drive Cover Screws in the corners of the drive.

**Note:** Ensure that the keypad cable is not being pinched between the drive and keypad.

## TROUBLESHOOTING

### **WARNING**



Always disconnect power to the pump at the circuit breaker and disconnect the communication cable before servicing the pump. Failure to do so could result in death or serious injury to serviceman, pool users or others due to electric shock. DO NOT attempt to adjust or service without consulting your dealer or a qualified pool technician. Read the entire Installation & User's Guide before attempting to use, service, or adjust the pool filtering system or heater.

### Alerts and Warnings

The pump displays all alarms and warnings on the control panel display. When an alarm or warning condition exists, the corresponding light will be lit on the display.

All control panel buttons are disabled until the alarm or warning is acknowledged with the **Reset** button. Pressing the **Reset** button will clear the alarm once the fault condition has been resolved.

**Note:** The pump will not start if the impeller is rotating.

#### Power Out/OFF

The incoming supply voltage is less than 170 VAC. The drive faults to protect itself from over current. The drive contains capacitors that keep it powered up long enough to save the current run parameters. If power is restored during this process, approximately 20 seconds, the drive will not restart until completed.

#### Priming Failure

If the pump is not defined as primed within the "Max Priming Time" it will stop and generate a "Priming Alarm" for 10 minutes, then attempt to prime again. The "Max Priming Time" is set by the user on the priming menu as discussed on page 13. If the pump cannot prime within five attempts it will generate a permanent alarm that must be manually reset.

#### Overheat

If the drive temperature gets above 130°F (54.4°C) the pump will slowly reduce speed until the over temperature condition clears.

#### Thermal Mode

When active, the motor will run at the preset RPM until the drive internal temperature increases above the minimum. The pump's internal thermal protection is disabled when connected to an automation system. Thermal protection is provided by selecting YES at the ON WITH FREEZE portion of the circuit function menu in the IntelliTouch® control system. To re-enable the internal thermal protection, the power to the drive must be cycled off then back on. **Important: See explanation of Thermal Mode on page 16.**

#### Over Current

Indicated that the drive is overloaded or the motor has an electrical problem. The drive will restart 20 seconds after the over current condition clears.

#### Over Voltage

Indicates excessive supply voltage or an external water source is causing the pump and motor to rotate thereby generating an excessive voltage on the drives internal DC buss. The drive will restart 20 seconds after the over voltage condition clears.

#### Internal Error

Indicates that the self-monitoring motor control software has encountered an error. Clear the alarm and restart the pump. If this alarm persists, contact Pentair Technical Service at 1-800-831-7133.

## Troubleshooting Chart

Problem	Possible Cause	Corrective Action
<p><b>Pump failure.</b> (For alert display messages, refer to Alerts and Warnings on page 24).</p>	<p>Pump will not prime - Air leak in suction. PRIME ERROR may be displayed.</p> <p>Pump will not prime - Not enough water.</p> <p>Pump does not come out of priming mode.</p> <p>Pump completes priming mode too early, and/or there is still a large amount of air in the housing</p> <p>Pump strainer basket is clogged.</p> <p>Pump strainer gasket is defective.</p>	<p>Check suction piping and valve glands on any suction gate valves. Secure lid on pump strainer pot and be sure lid gasket is in place. Check water level to be sure skimmer is not drawing air.</p> <p>Be sure the suction lines, pump, strainer, and pump volute are full of water.</p> <p>Adjust priming range to a higher setting (default setting is 5).</p> <p>Adjust priming range to a lower setting (default setting is 5).</p> <p>Clean pump strainer pot.</p> <p>Replace gasket.</p>
<p><b>Reduced capacity and/or head.</b> (For alert display messages, refer to Alerts and Warnings on page 24).</p>	<p>Air pockets or leaks in suction line. PRIMING FAILURE may be displayed.</p> <p>Clogged impeller. PRIMING FAILURE may be displayed.</p> <p>Pump strainer pot clogged. PRIMING FAILURE may be displayed.</p>	<p>Check suction piping and valve glands on any suction gate valves.</p> <p>Turn off electrical power to the pump. Remove the (6) bolts that holds the housing (strainer pot/volute) to seal plate. Slide the motor and seal plate away from the volute.</p> <p>Clean debris from impeller. If debris cannot be removed, complete the following steps:</p> <ol style="list-style-type: none"> <li>1. Remove diffuser and o-ring.</li> <li>2. Remove reverse-thread impeller screw and o-ring.</li> <li>3. Remove, clean and reinstall impeller.</li> <li>4. Reinstall reverse-thread impeller screw and o-ring.</li> <li>5. Reinstall diffuser, and o-ring.</li> <li>6. Reinstall motor and seal plate into volute.</li> <li>7. Reinstall seal plate nuts and volute and tighten securely.</li> </ol> <p>Clean suction trap.</p> <p>Clean pump strainer pot.</p>
<p><b>Inadequate circulation.</b> (For alert display messages, refer to Alerts and Warning on page 24).</p>	<p>Filter or pump basket dirty.</p> <p>Suction/discharge piping is too small.</p> <p>Speed is set too slow for proper filtration cycle.</p>	<p>Check trap basket; if plugged, turn pump off and clean basket.</p> <p>Check and clean pool filter.</p> <p>Increase piping size.</p> <p>Increase filtration run time.</p>

## Troubleshooting Chart, (continued)

Problem	Possible Cause	Corrective Action
<p><b>Electrical problem.</b> (For alert display messages, refer to Alerts and Warning on page 24).</p>	<p>Could appear as a “Low Voltage” alarm.</p> <p>Could appear as “Over Heat” alert.</p>	<p>Check voltage at motor terminals and at panel while pump is running. If low, see wiring instructions or consult power company.</p> <p>Check for loose connections.</p> <p>Check line voltage; if less than 90% or more than 110% of rated voltage consult a licensed electrician.</p> <p>Increase ventilation.</p> <p>Reduce ambient temperature.</p> <p>Tighten any loose wiring connections.</p> <p>Motor runs too hot. Turn power to motor off.</p> <p>Check for proper voltage.</p> <p>Check for proper impeller or impeller rubbing.</p>
<p><b>Control panel LCD screen displays sporadically or flickers on/off.</b></p>	<p>Loose drive wiring connection.</p>	<p>Check the connection between the drive and keypad. See image on page 3. The drive wiring connection should be tight.</p>
<p><b>Mechanical troubles and noise.</b></p>	<p>The pump motor is running but with loud noise.</p> <p>Foreign matter (gravel, metal, etc.) in pump impeller.</p> <p>Cavitation.</p> <p>Squeaking noise, especially evident at pump start-up or slow down.</p>	<p>If suction and discharge piping are not adequately supported, pump assembly will be strained. Do not mount pump on a wooden platform! Securely mount on concrete platform for quietest performance.</p> <p>Disassemble pump, clean impeller, follow pump service instructions for reassembly.</p> <p>Improve suction conditions.</p> <p>Increase pipe size.</p> <p>Decrease number of fittings.</p> <p>Increase discharge pressure.</p> <p>Inspect motor slinger and motor shaft seal behind the slinger (NOT the pump’s mechanical seal). Apply lubrication to the motor shaft rubber seals.</p>
<p><b>Pump does not respond to IntelliTouch, EasyTouch, SunTouch, IntelliComm system commands.</b></p>	<p>Improper automation setup.</p> <p>Communication network inoperative.</p>	<ol style="list-style-type: none"> <li>1. Be sure that the communication cable is connected at both ends.</li> <li>2. Check that the pump local address matches with the address used in the IntelliTouch control system.</li> <li>3. Check that the pump has been assigned a circuit name on the IntelliTouch control system.</li> <li>4. Ensure that the pump display says “DISPLAY NOT ACTIVE”.</li> </ol> <p>A defective device on the network can inhibit the proper operation of other network device. Devices should be disconnected sequentially until the network starts working.</p>

# REPLACEMENT PARTS

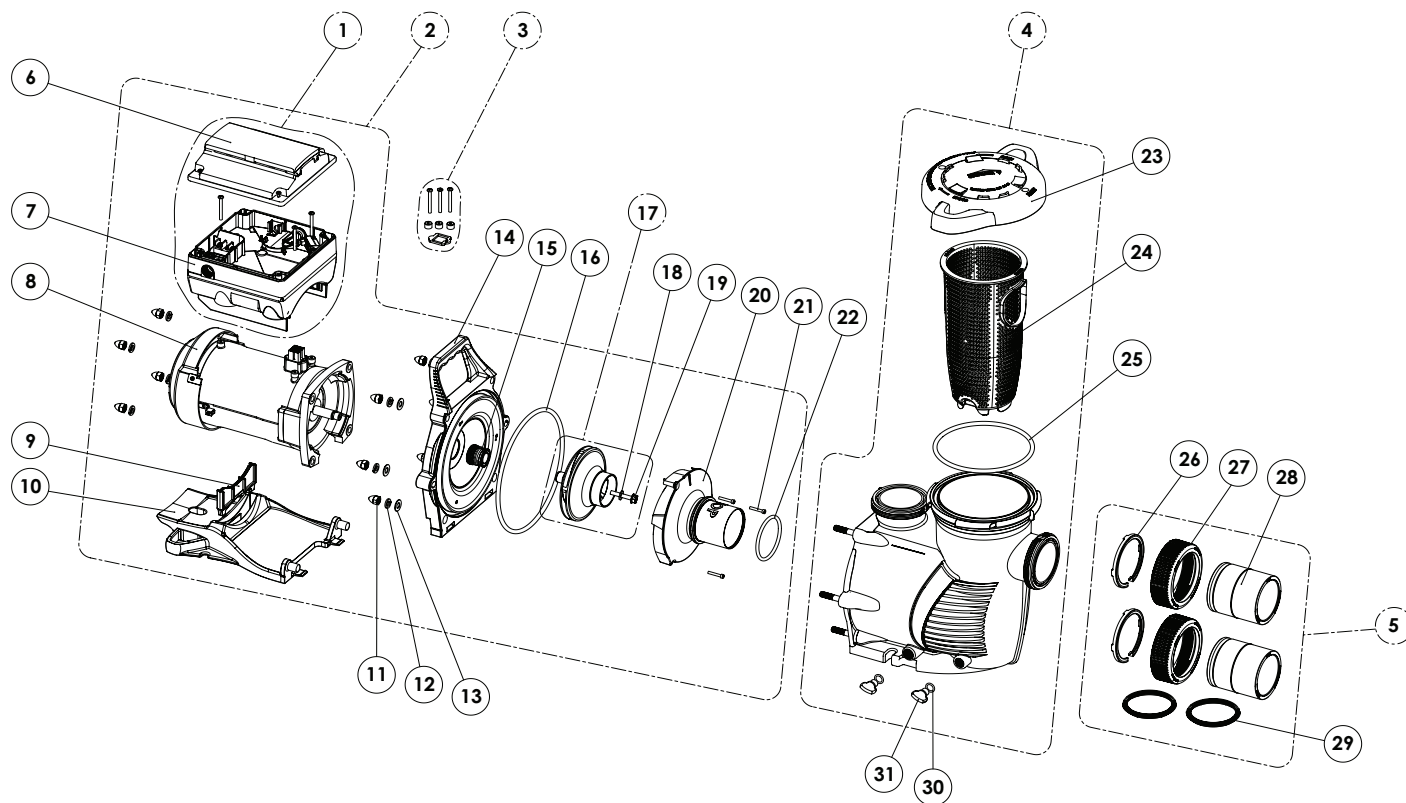

Item No.	Description	IntelliFloXF Part #	IntelliProXF Part #
1	Drive Kit	356879Z	356893Z
2	Power End Kit	400655Z	401655Z
3	Drive Hardware Kit	355685	
4	Wet End Assembly	400000	401000
5	Union Kit w/o Tap	410020	
6	Keypad Assembly Kit	357527Z	358527Z
7	Drive	356878Z	356892Z
8	Motor	350305S	350306S
9	Motor Base Insert	070929	357160
10	Motor Base	400004Z	401004Z
11	Acorn Nut (Qty. 10)	071413	
12	Lock Washer (Qty. 10)	U43-12SS	
13	Flat Washer (Qty. 6)	072184	
14	Seal Plate	400002	401002
15	Mechanical Seal	17351-0101S	
16	Seal Plate O-ring	351446	
17	Impeller Assembly	400023Z	
18	Impeller Screw Washer	072172	
19	Impeller Screw, Plastic-Head (pumps mfg. before 10/7/19)	37337-6080	
	Impeller Screw, Metal-Head (pumps mfg. after 10/7/19)	356073	

Item No.	Description	IntelliFloXF Part #	IntelliProXF Part #
20	Diffuser	400010	
21	Diffuser Screws	353323	
22	Diffuser O-ring	350336	
23	Lid/Locking Ring Assembly	400006	401006
24	Strainer Basket	400007Z	
25	Lid/Locking Ring O-ring	35505-1440	
26	Union C-clip (Qty. 2)	410001	
27	Union Nut (Qty. 2)	411000	
28	Union Adapter w/o Tap (Qty. 2)	410002	
29	Diamond Seal Kit (Qty. 2)	410016Z	
30	Drain Plug O-ring (Qty. 2)	192115	
31	Drain Plug (Qty. 2)	071131	357161
-	Keypad Relocation Kit	356904Z	356905Z
-	Seal Plate Kit w/ Mechanical Seal	400031Z	400032Z
-	50 ft. Communication Cable	350122	

(-) Not Shown

## Pump Performance Curves

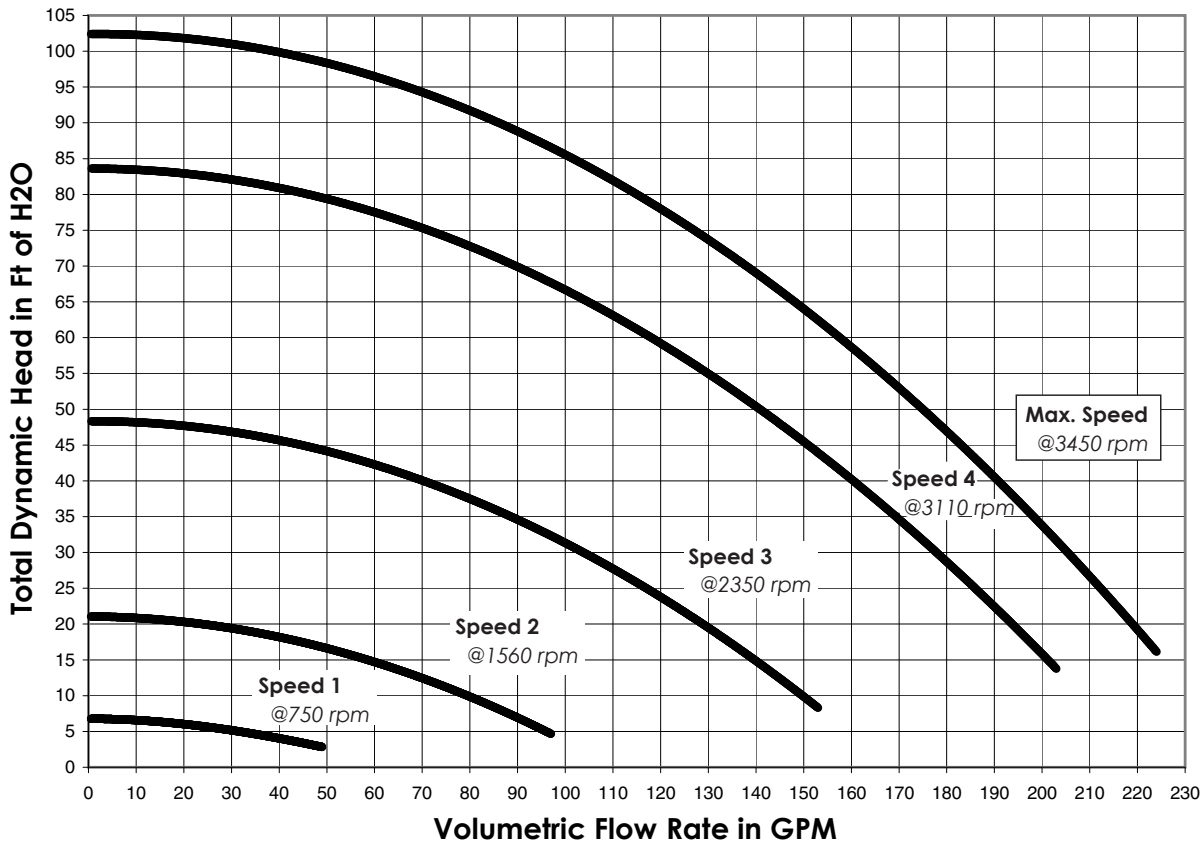

## Electrical Specifications

Circuit Protection: Two-pole 20 AMP device at the Electrical Panel.

Input: 230 VAC, 50/60 Hz, 3200 Watts Maximum, 1 phase

WEF 5.6 THP 3.95

## Pump Dimensions

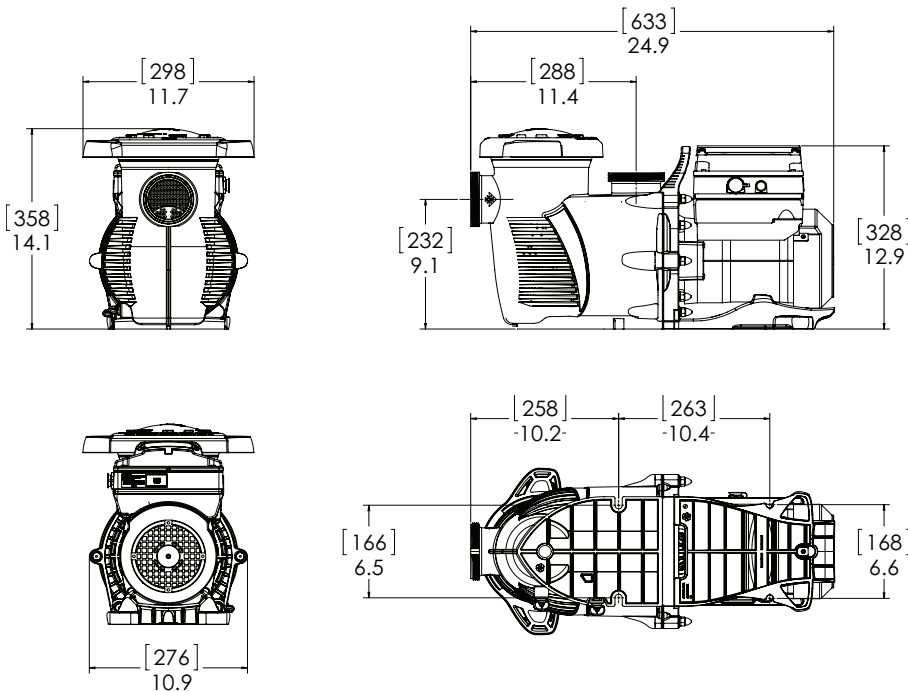



# Pump Menu Quick Reference Guide

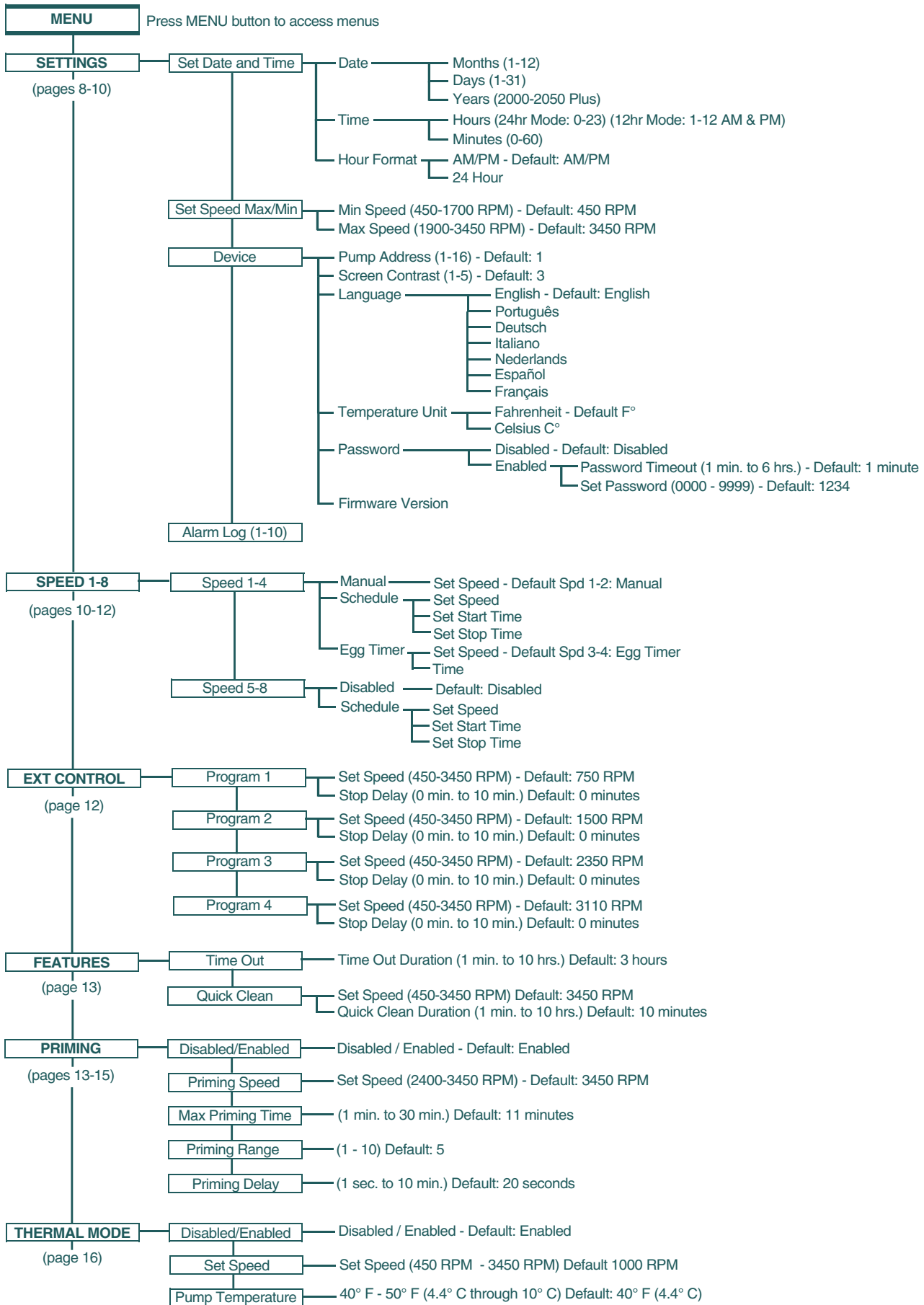

# NOTES

---

# NOTES



LIT. PKG. P/N 356901



1620 HAWKINS AVE., SANFORD, NC 27330 • (919) 566-8000  
10951 WEST LOS ANGELES AVE., MOORPARK, CA 93021 • (805) 553-5000

All indicated Pentair trademarks and logos are property of Pentair. Third party registered and unregistered trademarks and logos are the property of their respective owners.

© 2022 Pentair. All rights reserved. [WWW.PENTAIR.COM](http://WWW.PENTAIR.COM)



P/N 356902 REV. E 10/12/22