

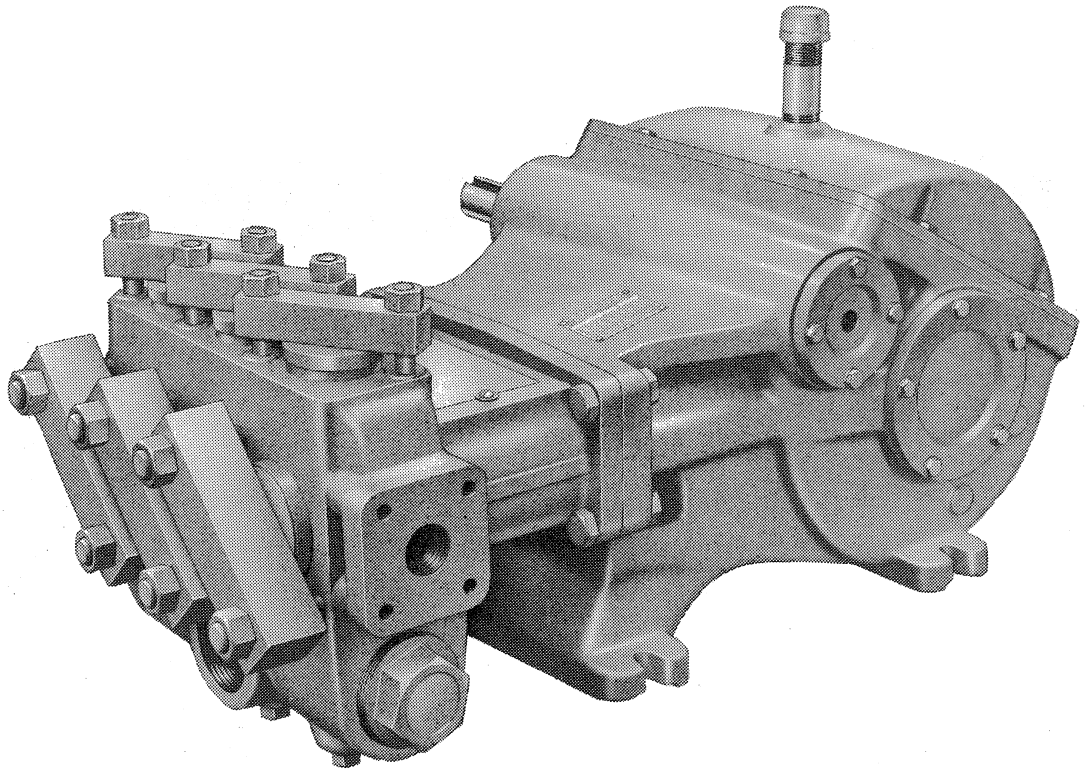

MYERS®



D65-16 AND D65-20 SERIES **RECIPROCATING PUMPS**

NOTE! To the installer: Please make sure you provide this manual to the owner of the equipment or to the responsible party who maintains the system.

GENERAL INSTRUCTIONS

CAUTION: Positive Displacement Pumps must have a proper size and operable type of pressure regulating valve or pressure relief valve piped into the discharge line. This is mandatory to prevent damage to pump and piping or possible injury to personnel. Do not install any valves or shutoff devices in the by-pass line from pressure regulator to tank or supply.

CAUTION: All pumps should be installed level. For mobile applications the maximum angle of intermittent operation should be no more than 5 degrees in any one direction.

CALIFORNIA PROPOSITION 65 WARNING:

▲ WARNING This product and related accessories contain chemicals known to the State of California to cause cancer, birth defects or other reproductive harm.

BELT DRIVE

With belt drives, the pulley on both the engine and pump should be located as close as possible to bearing to reduce bearing and shaft bending loads. On multiple V-belt drives, a complete set of belts should be installed when making a replacement. Make sure that all bolts, nuts, set screws and keys are properly tightened.

STARTING PUMP

Fill pump crankcase with recommended oil to level mark on oil saber. Oil recommendations are covered in lubrication section of pump instructions. Replace all drain plugs in pump and piping. Inspect tank to be sure that no foreign material is in tank or suction line. Fill tank at least half full or connect suction to water supply. Open valve (if present) in suction line. Avoid prolonged dry operation which may cause excessive wear on cylinders piston packing. Be sure that an operating pressure gauge is located in discharge line. Make sure all valves, including spray gun or nozzles, are open in discharge line. Spray gun may be anchored to discharge back into tank. Completely back off pressure adjusting screw on pressure regulating valve.

After starting, close discharge valve or spray gun slowly while watching pressure gauge to make sure relief valve or unloader is operating properly. Adjust relief valve or unloader to desired pressure. See regulator instructions. Cycle nozzles, or gun, on and off to be sure that pressure adjustment and regulator operation is satisfactory. Nozzle capacity should not exceed 90% of pump capacity for satisfactory regulator operation. AVOID FREEZING by draining all water from pump and system in cold weather.

SUGGESTED MAINTENANCE SCHEDULE

Check oil level – Daily

Drain & change oil – 300 hr.
Drain at operating temperature to prevent contamination from settling.

Replace piston packing – 500 hr.
Inspect frequently for leakage; piston packing is allowed to drip in order to cool and lubricate packing.

Inspect valves and springs – 500 hr.
Replace if cracks and heavy wear are present.

Inspect connecting link bearing inserts – 1000 hr.
Replace at first signs of fatigue or wear to prevent damage to crankshaft.

Inspect crankshaft tapered roller bearings – 2000 hr.

LUBRICATION

Fill gear case with Mobilgear 630 or equal additive to approximately 5 1/2 qts. Adjust by viewing the oil level at mark on oil dipstick.

NOTE: After first 30 hours of operation drain oil from gear case (preferably drain at operating temperature), replace plug and refill crankcase with new oil. Check oil level daily and add oil as needed.

ADDITIVES FOR CRANKCASE OIL

Use of Molybdenum Disulfide (MoS₂) is highly recommended as an additive to the gear case oil in back geared pumps and speed reducers. The additive is compatible with all known oils. It is effective in reducing wear and friction that power train life may be doubled between overhauls.

- Volume MoS₂ concentrate or dispersion “M” for 5% – 9 oz.
- Volume MoS₂ concentrate or dispersion “M” for 10% – 18 oz.

SERVICE

Disengage clutch, disconnect electrical leads to motor, or remove spark plug leads on engine.

REPLACING PACKING

Move assembly to front end of cylinder (top dead center). Remove valve assembly if required to provide clearance. Remove cap screw. Retract piston rod and insert tool. Pull packing assembly out or push by rotating crankshaft by hand.

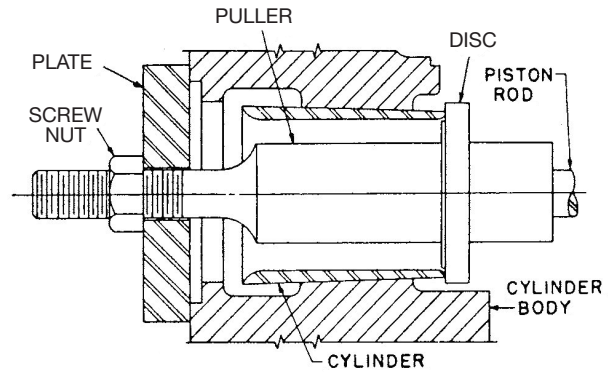
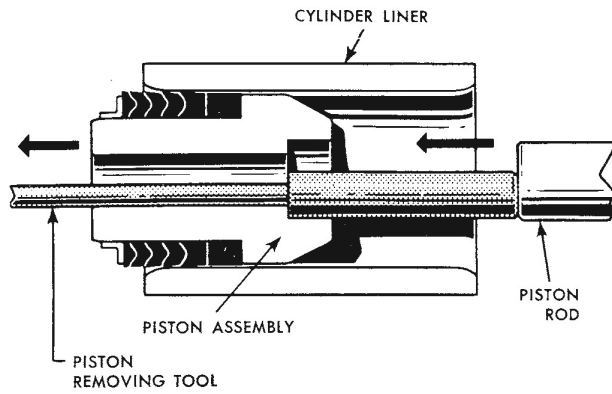

Inspect cylinders for linear grooving. If any is detected, replace cylinders. New packing will rapidly cut or wear out in grooved cylinders.

Assemble V-rings onto stud and lubricate the outside of the assembly with Molykote® or other grease for ease in insertion – do not use a graphite-type grease.

When installing each V-ring assembly, rotate crankshaft until piston rod is at forward position. Place copper gasket in position in stud using a small amount of Permatex® to hold in place.

Assemble capscrew, etc., into piston assembly and push into cylinder. Torque the cap screw to 50 ft/lbs.

REPLACING CYLINDERS

Remove packing and rotate crankshaft until piston rod is in rear position. Insert puller through inside of cylinder and pilot over piston rod. Insert disc into slots on puller and slip plate over threads on puller. Screw nut on thread of puller and snug up. Tighten nut until cylinder breaks loose. Loosen nut and slip disc out of slots. Remove puller and repeat to remove other cylinders.

Reasonable care and judgment should be used when installing the new cylinder. Clean out any accumulation of loose rust or corrosion in cylinder body. Install a new O-ring in groove on tapered portion of cylinder and lubricate with oil or grease. Position cylinder carefully by hand to avoid cutting the O-ring. Drive into position firmly, but never use a hydraulic press as excessive force can cause damage and make cylinders very difficult to remove for later replacement.

REPLACING VALVE SEATS - D65-16 SERIES

First remove spring retaining bar, spring and flat valve. When removing upper valve seat, pass head of puller through hole in valve seat before sliding wedge is inserted alongside puller bolt. Draw down on nut at top of bolt. When removing lower seats, drop puller bolt through opening for upper seat and remove in same manner. Using sliding wedge on pumps where lower seats are the same size as upper seats.

Place new lower seat in tapered hole in cylinder body. Hold a soft brass or hardwood round bar against seat and drive into place. The knocker stem is in two pieces so that it can be shortened for installing discharge seats after suction seats have been installed.

V-RING PISTON ASSEMBLY

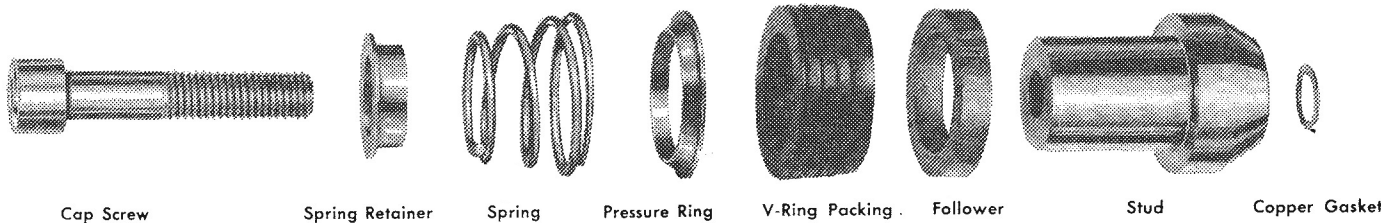

REMOVING AND REPLACING SEATS: CENTER POST VALVES - D65-20 SERIES

Remove valve and cylinder caps which provide access to both suction and discharge valves. Remove the stainless steel shoulder screw which serves as a valve guide and spring retainer. Remove shoulder screw, spring retainer, spring and valve from the pump fluid end.

Assemble stud, retainer and three large screws by inserting screw heads thru holes in valve seat. Rotate retainer to the right until heads catch and secure in place by screwing stud firmly. Place plate over stud, screw on nut and torque slowly with wrench until seat breaks loose.

Suction valve seats are removed as above, except two stud lengths are joined using coupling.

TO REPLACE

Inspect tapered valve seat bore in fluid end for rust and wipe out excess with a rag. Place a new lower seat in tapered hole. Drive lower seat firmly into place and repeat for upper seat being sure to also inspect the tapered bore for rust.

Reassemble valve, spring and spring retainer. Confirm that springs are in correct location. Be sure that shoulder screw is bottomed in valve seat. This screw is furnished with a Nylock locking pellet to prevent accidental loosening of screw. Also be certain that valve disc is installed on the valve with the flat face down. Inspect O-rings on valve and cylinder caps. Replace if O-rings show signs of wear.

NOTE FOR ALL D65 SERIES: Reassemble valve spring in correct location. When upper and lower valve seats are the same size, the heavier spring (larger diameter wire) is always installed on upper or discharge valve.

REPLACING PISTON ROD SEALS

The rod seal assembly contains two seals and two oil seals with lips facing power end. The oil seal can be replaced without taking the fluid end off by removing the cylinder and piston to allow access for oil seal housing. Unscrew two Allen screws and place into the other two tapped holes. Gradually screw them in to push oil seal housing off the retainer. After assembling new seals in oil seal housing, an assembly thimble should be used on the end of the crosshead rod for sliding the oil seal housing back into retainer. Check gasket and replace if damaged.

An assembly thimble should be used on the small end of the piston rod to expand sealing edge as it is pushed on. The thimble should be machined from high carbon steel and polished on the exterior to reduce possibility of seal lip damage.

REMOVING CRANKSHAFT AND PINION SHAFT

Remove packing assemblies and remove connecting link caps. Move the link-crosshead assembly as far forward as possible. On some models, it may be necessary to remove the fluid cylinder body to obtain clearance for crankshaft removal.

Secure separation of the crankshaft gear and gear case so that crankshaft will be held in place against pinion shaft. Remove both crankshaft bearing caps. Hold crankshaft at ring gear and left-hand link journal to prevent dropping into bearing bores. Remove from gear case by moving crankshaft to the right until left end can be swung free.

To remove pinion shaft, observe inside of gear case to see if small sheet metal plates are in front of each bearing. These plates must be removed prior to bearing caps.

Tap the end of the pinion shaft extension to remove the bearing cup at the opposite end. After removing pinion shaft, the remaining bearing cup can be removed by gently tapping against the peripheral edge of the cup with a brass rod.

REPLACING PINION SHAFT AND SHIMMING BEARINGS

After installing the link-crosshead assemblies and moving them toward the fluid end as far as possible, tap the right-hand pinion shaft bearing cup into position using the bearing cap. Make sure that the spacer is properly seated on drive end of pinion shaft. The curve side should match the fillet radius of pinion shaft. Place pinion shaft in position and tap left-hand bearing cup into place.

Cover the shaft keyway to protect lip of oil seal. Slide on the open bearing cap with a .030" shim. Tighten the four cap screws to recommended torque.

Install other cap using total shim thickness. Tighten cap screws holding pinion or crankshaft caps to gear case. Rotate pinion shaft back and forth, applying about 15 lbs. axial force to properly seat tapered rollers. Measure end-play by using an indicating gauge.

Subtract recommended end-play (.005" – .009") from actual end-play. This is the amount of shim that must be removed. After excess shim thickness has been removed, replace caps and retighten cap screws. Measure end-play, and if end-play is not within limits recommended, add or subtract shims as required.

Pinion bearing shims are made of .002" layers bonded together. Start separation of layers by heating edge, then peel back.

REPLACING PINION SHAFT AND SHIMMING BEARINGS ON HYDRAULIC DRIVEN PUMPS

Press bearing cones onto both ends of the pinion shaft, being sure bearing seats completely against stop on shaft. Place pinion and bearing cone assembly into the crankcase, positioning the pinion gear over the crankshaft gear. Carefully press bearing cups into both sides of the crankcase. Tap cups until bearing cups and cones are completely together and pinion is in the proper location in the crankcase. Press shaft seal into cap, bearing and seal plate. Be sure both caps are installed with the lip towards the center of the pump. Install right bearing cap with two .003" thick shims and tighten. Install left bearing cap with one .015" thick shim, and one .003" thick shim and tighten. Rotate pinion shaft back and forth, applying about 15 lbs. axial force to properly seat the tapered rollers. Measure end-play by using an indicating gauge. Subtract recommended end-play (.005" – .009") from actual end-play. This is the amount of shim that must be removed. After excess shim thickness has been removed, replace left cap and retighten cap screws. Measure end-play again and repeat if necessary.

REPLACING CRANKSHAFT AND SHIMMING BEARINGS

Press the bearing cups into the caps. Place one cap into position on the right side with cap screws engaged about one turn. Install crankshaft (left end first), and push both bearing caps into place. Extreme care should be exercised to avoid damage to gear teeth, bearings, and link journals.

For quiet operation and long life, the crankshaft and bearings must be installed with .003" to .005" preload. To adjust, loosen the four cap screws on the pinion shaft bearing cap.

Place about a .045" shim on the right crankshaft bearing cap, and tighten the five cap screws. Install the left cap without shims and secure with two cap screws. Torque at 13 ft/lbs and rotate the crankshaft. Retorque the cap screws. Repeat three times to properly seat the tapered roller bearings. Measure (adjacent to the cap screws) the shim gap remaining between the bearing cap and the gear case. The required shim thickness for this cap is equal to the average gap measurement plus .022". Insert correct shim thickness under left bearing cap and tighten cap screws. Install connecting links and caps, then torque cap screws to 40 ft/lbs.

IMPORTANT – Check for adequate side clearance of links on crankshaft. Some shims must be moved from one end to the other until sideways movement of all links can be seen.

Check torque of cap screws on all bearing caps.

RECONDITIONED CRANKSHAFTS

When the crank throws are slightly damaged, they can sometimes be reconditioned for further use. This can be done by sandpapering and polishing until all ridges are completely removed. The final polishing operation should be with very fine emery cloth. If the surface is badly damaged, the crankshaft can often be salvaged by "metalizing" the crank throw, regrinding and polishing to the original diameter.

SERVICING CONNECTING LINKS

The connecting rod link is furnished with replaceable split sleeve bearing inserts at the crank throw. Do not attempt to re-fit connecting links to the crankshaft bearings by filing or grinding the mating faces of the link cap where it contacts the link. Always be sure that the proper side of the link is placed upward when attaching it to the crankshaft. The upper side contains an oil hole at the crosshead end of the link. This oil hole must be up to allow proper oil feeding to the crosshead pin bushing. The wrist pin is press-fitted into the crosshead and slip-fitted through the bronze bushing. Use arbor press to force in the wrist pin, checking to see if the link is free to rotate after the wrist pin is pressed in. Verify that both sides of the wrist pin do not protrude beyond the crosshead.

The crosshead end of the connecting link is fitted with a bronze bushing. New replacement link bushings are reamed to the proper size for immediate installation. If only the bushing is replaced, it may be necessary to ream the new bushing to the proper inside diameter after it is pressed into the link. When placing the bushing on the link, be sure that the oil holes in the bushing and link are in line after the bushing is pressed into position.

CROSSHEAD AND PISTON RODS

Repair parts for the crosshead and piston rod are supplied as a complete unit. If either of these parts becomes worn it is necessary to replace both the crosshead and piston rod. Under normal conditions a crosshead will not wear, nor will the bore of the crankcase wear to the extent that oversize crossheads will be required. A clearance of .002" to .004" is standard for the crosshead.

RECOMMENDED TORQUE (foot-pounds)

FASTENER LOCATION
Link Bearing Caps - 40
Crankshaft End Caps - 20
Pinion Bearing End Caps - 20
Cap Screw, Piston Assembly to Piston Rod - 50
Valve Cap Clamps - 100
Cylinder Cap Clamps - 175

D65-16 SERIES

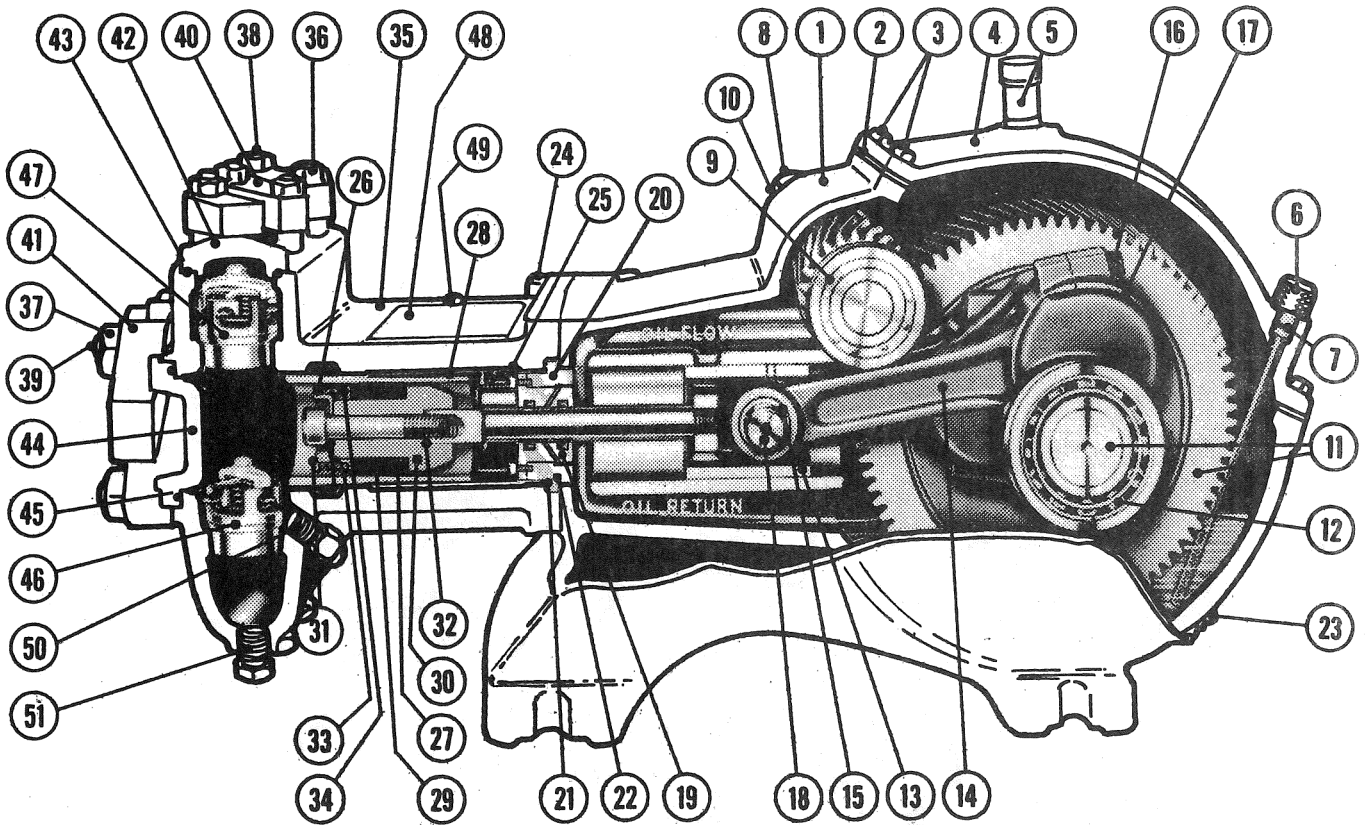

D65-16 SERIES PARTS LIST

Item	Description	Qty.	Eng. No
1	CASE, GEAR	1	04625E001
2	GASKET, LID	1	06201C000
3	SCREW, CAP, 5/16"-18 UNC x 7/8", STEEL	8	19100A005
4	LID	1	04561B000
5	NIPPLE, SPECIAL VENT	1	17995A000
	CAP, PIPE	1	05737A002
6	GAUGE, OIL, WITH O-RING	1	17360A010
7	O-RING 3/8" I.D., 9/16" O.D., 1/16" THICK	1	110-000110-201
8*	SHAFT, PINION	1	27938B020
	SPACER	1	20164B002A
	SHIM	4	05231A074
	SHIM	4	05231A075
9	CONE, BEARING	2	05674A013
	CUP, BEARING	2	05675A009
10	CAP, OPEN	1	04563A001
	CAP, CLOSED	1	04741B001
	OIL SEAL	1	05710A017
	SCREW, CAP, 3/8"-16 UNC x 1", STEEL	18	19101A013
	WASHER, SEAL	18	14946A003
11*	CRANKSHAFT	1	27937C022
12	CONE, BEARING	2	05674A018
	CUP, BEARING	2	05675A013
	CAP, BEARING	2	04624B004
	SHIM, PLASTIC, GREEN, 6-7/32" x 5-1/32" x .0115"	6	05068A016
	SHIM, PLASTIC, PINK, 6-7/32" x 5-1/32" x .003"	6	05068A018
	O-RING, 5" I.D., 5-1/8" O.D., 1/16" THICK	2	05876A098
13	CROSSHEAD	3	06211B041
14	LINK, DUCTILE IRON	3	17042C002
15	BUSHING	3	B01619A000
16	SCREW, CAP	6	19103A016
	LOCK WASHER	6	05454A004
17	BEARING, TWO HALVES	3	15245A101
18	WRIST PIN	3	M01525A001
19	HOUSING, OIL SEAL	3	24959A001
	OIL SEAL	6	22835A004
20	RETAINER, OIL SEAL HOUSING	3	24958A000
	SCREW, ALLEN	6	06106A034
	GASKET, SEAL HOUSING	3	05059A434
	KIT FOR REF. NO. 19 & 20	1	24648A000
21	SPRING	3	M1643A000
22	GASKET	3	05059A058
23	PLUG, PIPE, MAGNETIC	1	17481A002
24	SCREW, CAP, 3/4"-10 UNC x 3", STEEL	4	06106A038
	NUT, HEX 3/4"-10 UNC, STEEL	4	19109A050
	LOCKWASHER	4	05454A003
25	SCREW, CAP, 5/8"-11 UNC x 2", STEEL	4	19105A008
26	SCREW, CAP, .551"-14 METRIC x 2-3/4"	3	16654A006
	SCREW, CAP, .551"-14 METRIC x 3", 316 SST FOR AVAB-CP PUMP	3	16654A008
27	FOLLOWER	3	20855A000
28	LINER, CYLINDER, 316 SST	3	20851A002
	O-RING, CYLINDER (INCL. W/LINER)	3	05876A095
	WASHER, SPLASH	3	05059A418

* NOTE: When purchasing the crankshaft or pinion on units built prior to 07/12,
both items will need to be replaced due to an improvement in design.

STYLE VALVE ASSEMBLY		Y	Z	Z
SUCTION VALVE ASSEMBLY		11903A004K	18925A003	18925A013K
DISCHARGE VALVE ASSEMBLY		11903A003K	18925A004K	18925A014K
SEAT MATERIAL		420F	420F	316

	Description	Qty.	Eng. No		
A	VALVE SEAT	6	06271A000	18835A002	18835A004
B	VALVE	6	17553A002	18834A001	18834A001
C	SPRING, VALVE, SUCTION	3	18463A000	18463A000	18463A000
	SPRING, VALVE, DISCHARGE	3	11829A000	11829A000	11829A000
D	RETAINER, SPRING, VALVE	6	11827A000	18833A001	18833A001
E	CLAMP, RETAINER, SPRING	6	11828A000	-	-
F	LOCK NUT OR CAP SCREW	6	11904A001	18832A000	18832A001

Item	Description	Qty.	Eng. No
28	PLUG, PIPE, 1-1/4"	1	05022A047
	PLUG, PIPE, 3"	2	03210A000
	LINER, CYLINDER 316 SST FOR AVAB-CP PUMP	3	20851A002
	O-RING, CYLINDER (INCL. W/LINER)	3	05876A095
	WASHER, SPLASH	3	05059A418
	PLUG, PIPE, 1-1/4" ALUM. BRONZE	1	05022A065
	PLUG, PIPE, 3" ALUM. BRONZE FOR AVAB & AVAB-CP PUMP	2	03210A010
29	PACKING V-RINGS	3	18922A004
30	STUD, 2-9/16" x 2-1/16" x 1-1/2", 316 SST	3	20850A000
	STUD, 2-9/16" x 2-1/16" x 1-1/2", 316 SST FOR AVAB-CP PUMP	3	20850A010
31	RETAINER	3	20852A000
	RETAINER	3	20852A001
32	WASHER	3	05030A128
33	SPRING	3	20853A000
34	RING	3	20854A000
	RING 316 SST FOR AVAB-CP PUMP	3	20854A001
35	BODY, CYLINDER	1	18639F002
	BODY, CYLINDER, ALUM. BRONZE FOR AVAB & AVAB-CP PUMP	1	18639F004
	O-RING, 2-3/4" x 2-15/16" x 3/32"	3	05876A095
36	NUT, HEX, 5/8"-11 UNC, STEEL	6	19109A046
37	NUT, HEX, 7/8"-14 UNF, STEEL	6	19109A072
38	STUD, 5/8"-11 UNC x 3-5/16"	6	05659A560
39	STUD, 7/8"-14 UNF X 4-1/2"	6	05659A089
40	CLAMP, VALVE CAP	3	20848A000
41	CLAMP, CYLINDER CAP	3	20856A000
42	CAP, VALVE	3	17390A000
	CAP, VALVE, ALUM. BRONZE FOR AVAB & AVAB-CP PUMP	3	17390A002
43	O-RING, 2-3/8" x 2-9/16" x 3/32"	3	05876A064
44	CAP, CYLINDER	3	20849A000
	CAP, CYLINDER, ALUM. BRONZE FOR AVAB & AVAB-CP PUMP	3	20849A001
45	O-RING, 3-1/4" x 3-1/2" x 1/8"	3	05876A096
46	ASSEMBLY, VALVE, SUCTION: D65-16AVD, D65-16AVD-L & D65-16AVAB "Y"	3	11903A004
	ASSEMBLY, VALVE, SUCTION: D65-16AVD-CP "Z"	3	18925A003
	ASSEMBLY, VALVE, SUCTION: D65-16AVAB-CP "Z" 316	3	18925A013
47	ASSEMBLY, VALVE, DISCHARGE: D65-16AVD, D65- 16AVD-L & D65-16AVAB "Y"	3	11903A003
	ASSEMBLY, VALVE, DISCHARGE: D65-16AVD-CP "Z"	3	18925A004
	ASSEMBLY, VALVE, DISCHARGE: D65-16AVAB-CP "Z" 316	3	18925A014
48	LID, CYLINDER	1	M01520A000
49	SCREW, MACHINE 1/4"-20 UNC x 1/2"	2	148850001
	WASHER	2	05030A020
50	PLUG, PIPE, 1/2"	3	05022A015
	PLUG, PIPE, 1/2" FOR AVAB PUMP	3	05022A035
	PLUG, PIPE, 1/2" 316 SST FOR AVAB & AVAB-CP PUMP	3	05022A063
51	PLUG, PIPE, 1"	3	05022A043
	PLUG, PIPE, 1" FOR AVAB PUMP	3	06206A000
	PLUG, PIPE, 1" ALUM. BRONZE FOR AVAB & AVAB-CP PUMP	3	05022A064

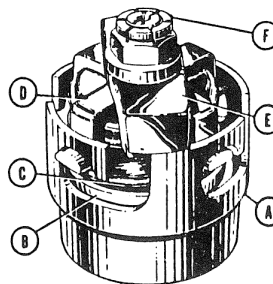

VALVE Y

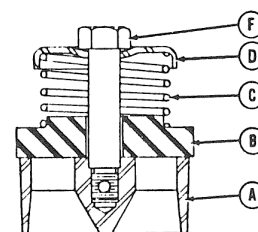

VALVE Z

D65-16AVD-AF/AFL SERIES

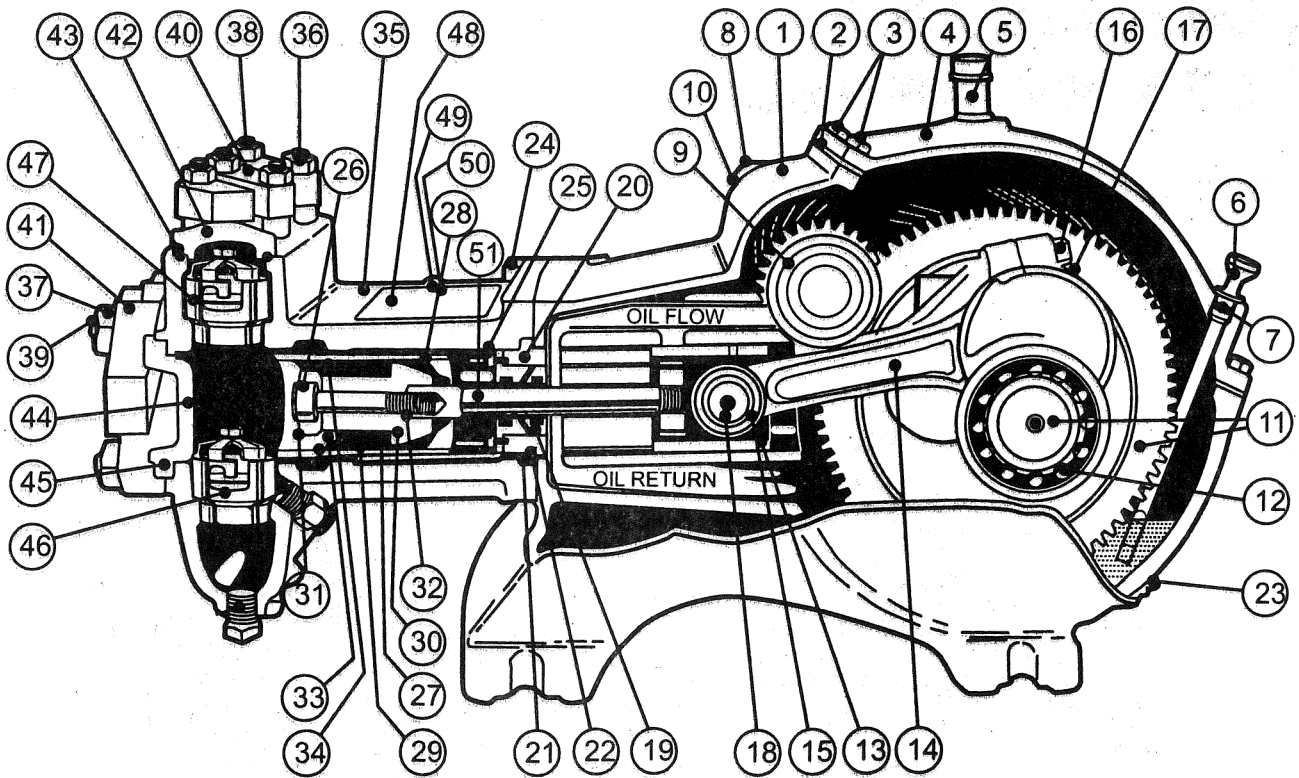

PARTS LIST

D65-16AVD-AF (20160F027) Right Hand Drive D65-16AVD-AFL (20160F028) Left Hand Drive

Item	Description	Qty.	Eng. No
1	CASE, GEAR	1	04625E100
2	GASKET, LID	1	06201C000
3	SCREW, CAP, 5/16"-18 UNC x 7/8", STEEL	8	19100A005
4	LID	1	04561B000
5	NIPPLE, SPECIAL VENT CAP, PIPE	1 1	17995A000 05737A002
6	GAUGE, OIL, WITH O-RING	1	17360A010K
7	O-RING 5/6" I.D., 7/16" O.D., 1/16" THICK	1	05876A063
8*	SHAFT, PINION	1	27938B020
	SPACER	1	20164B022A
	KEY 3/8" x 3/8" x 2-1/2"	1	05818A048
	SHIM	4	05231A074
	SHIM	4	05231A075
9	CONE, BEARING CUP, BEARING	2 2	05674A013 05675A009
10	CAP, OPEN CAP, CLOSED OIL SEAL SCREW, CAP, 3/8"-16 UNC x 1", STEEL WASHER, SEAL	1 1 1 18 18	04563A001 04741B001 05710A017 19101A013 14946A003
11*	CRANKSHAFT/RING GEAR	1	27937C022
12	CONE, BEARING CUP, BEARING CAP, BEARING SHIM, PLASTIC, GREEN, 6-7/32" x 5-1/32" x .015" SHIM, PLASTIC, PINK, 6-7/32" x 5-1/32" x .003" O-RING, 5" I.D., 5-1/8" O.D., 1/16" THICK	2 2 2 6 6 2	05674A018 05675A013 04624B004 05068A018 05068A016 05876A098
13	CROSSHEAD	3	06211B041
14	LINK, DUCTILE IRON	3	17042C002
15	BUSHING	3	B0619A001
16	SCREW, CAP WASHER, LOCK	6 6	19103A016 05454A004
17	BEARING, TWO HALVES	3	15245A101K
18	WRIST PIN	3	M01525A001
19	HOUSING, OIL SEAL OIL SEAL	3 6	24959A001 22835A004
20	RETAINER, OIL SEAL HOUSING SCREW, ALLEN GASKET, SEAL HOUSING KIT FOR REF. NO. 19 & 20	3 6 3 1	24958A000 06106A034 05059A434 24648A000

Item	Description	Qty.	Eng. No
21	SPRING	3	M01643A000
22	GASKET	3	05059A058
23	PLUG, PIPE, MAGNETIC	1	17481A002
24	SCREW, CAP, 3/4"-10 UNC x 3" STEEL WASHER, LOCK	4 4	06106A038 05454A003
25	SCREW, CAP, 5/8"-11 UNC x 2", STEEL	4	19105A008
26	SCREW, CAP, .551"-14 METRIC x 2-3/4"	3	16654A006
27	FOLLOWER	3	20855A000
28	LINER, CYLINDER .316 SST PLUG, PIPE 1-1/4" PLUG, PIPE, 3"	3 1 2	20851A002 05022A047 03210A000
29	PACKING V-RINGS, AFLAS®	3	18922A013
30	STUD, 2-9/16" x 2-1/16" x 1-1/2", STAINLESS STEEL	3	20850A000
31	RETAINER	3	20852A000
32	WASHER	3	05030A128
33	SPRING	3	20853A000
34	RING	3	20854A000
35	BODY, CYLINDER O-RING, 2-3/4" x 2-15/16" x 3/32", VITON	1 3	18639F002 05876A095
36	NUT, HEX, 5/8"-11 UNC, STEEL	6	19109A046
37	NUT, HEX, 7/8"-14 UNF, STEEL	6	19109A072
38	STUD, 5/8"-11 UNC x 3-5/16"	6	05659A560
39	STUD, 7/8"-14 UNF x 4-1/2"	6	05659A089
40	CLAMP, VALVE CAP	3	20848A000
41	CLAMP, CYLINDER CAP	3	20856A000
42	CAP, VALVE	3	17390A000
43	O-RING, 2-3/8" x 2-9/16" x 3/32", VITON	3	05876A238
44	CAP, CYLINDER	3	20849A000
45	O-RING, 3-1/4" x 3-1/2" x 1/8", VITON	3	05876A196
46	ASSEMBLY, VALVE, SUCTION: D65-16AVD-AF D65-16AVD-AFL	3	11903A004K
47	ASSEMBLY, VALVE, DISCHARGE: D65-16AVD-AF D65-16AVD-AFL	3	11903A003K
48	LID, CYLINDER	1	M01520A000
49	SCREW, MACHINE 1/4"-20 UNC x 1/2" CLAMP	2 2	05028A002 26842A000
50	PLUG, PIPE, 1/2"	3	05022A015
51	PLUG, PIPE, 1"	3	05022A043

*NOTE: When purchasing the crankshaft or pinion on units built prior to 07/12,
both items will need to be replaced due to an improvement in design.

STYLE VALVE ASSEMBLY		Y	
SUCTION VALVE ASSEMBLY		11903A004K	
DISCHARGE VALVE ASSEMBLY		11903A003K	
SEAT MATERIAL		420F	
Description	Qty.	Eng. No	
A SEAT, VALVE	6	06271A000	
B VALVE	6	17553A002	
C SPRING, VALVE, SUCTION	3	18463A000	
SPRING, VALVE, DISCHARGE	3	11829A000	
D RETAINER, SPRING, VALVE	6	11827A000	
E CLAMP, RETAINER, SPRING	6	11828A000	
F LOCK NUT OR CAP SCREW	6	11904A001	

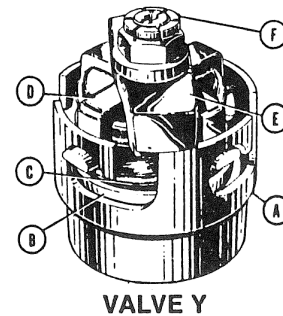

D65-20 SERIES

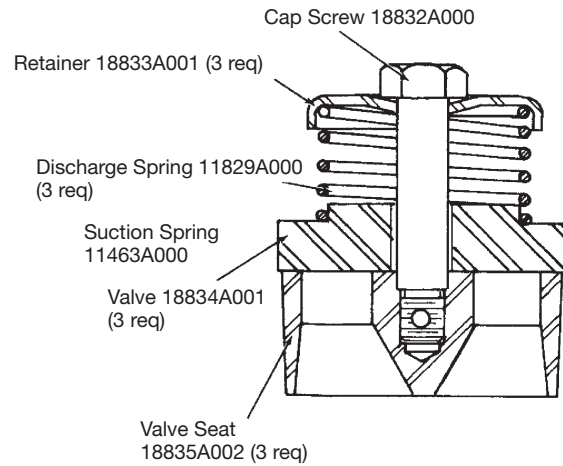
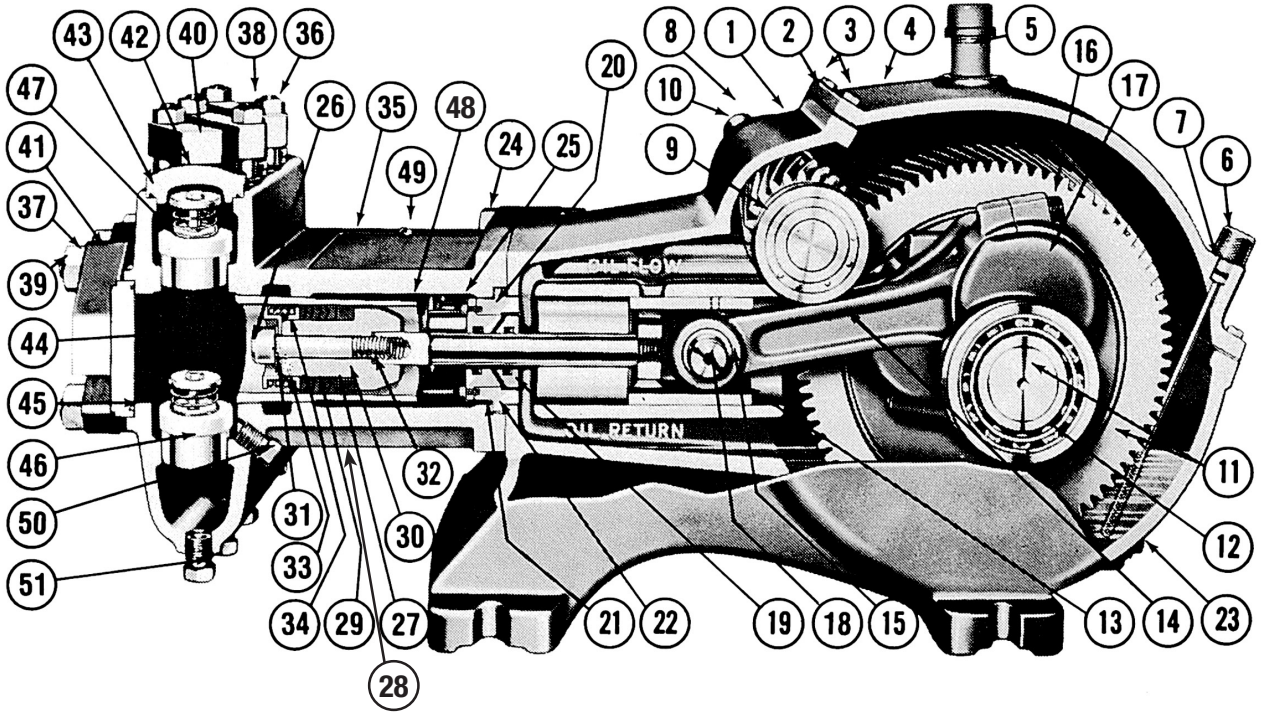

COMPLETE DISCHARGE VALVE AND SEAT 18925A004K
 COMPLETE SUCTION VALVE AND SEAT 18925A003K

D65-20 SERIES PARTS LIST

Item	Eng. No	Description	Qty.
1	04625E001K	CASE, GEAR	1
2	06201C000	GASKET, LID	1
3	19100A005	SCREW, CAP, 5/16"-18 UNC x 7/8", STEEL	8
4	04561B000	LID	1
5	17995A000	NIPPLE, SPECIAL VENT	1
	05737A002	CAP, PIPE	1
6	7206-0094-00K	DIPSTICK KIT WITH O-RING	1
7	110-000110-201	DIPSTICK	1
8	20164B020K	SHAFT, PINION (INCLUDES SPACER)	1
	20164B022A	SPACER	1
	05231A074	SHIM, GREEN, .003" THICK	4
	05231A075	SHIM, PINK, .015" THICK	4
9	05674A013	CONE, BEARING	2
	05675A009	CUP, BEARING	2
10	04563A001	CAP, OPEN	1
	04741B000	CAP, CLOSED	1
	05710A017	OIL SEAL	1
	19101A013	SCREW, CAP, 3/8"-16 UNC x 1", STEEL	18
	14946A003	WASHER, SEAL	18
11	20355C022K	CRANKSHAFT	1
12	05674A021	CONE, BEARING	2
	05675A013	CUP, BEARING	2
	04624B004	CAP, BEARING	2
	05068A016	SHIM, PLASTIC, PINK, 6-7/32" x 5-1/32" x .015"	6
	05068A018	SHIM, PLASTIC, GREEN, 6-7/32" x 5-1/32" x .003"	6
	05876A098	O-RING, 5" I.D., 5-1/8" O.D., 1/16" THICK	2
13	06211B041	CROSSHEAD AND PISTON ROD	3
14	17042C002	LINK, DUCTILE IRON	3
15	B01619A000	BUSHING	3
16	06171A010K	SCREW, CAP	6
	05454A004	LOCK WASHER	6
17	15245A101	BEARING, TWO HALVES	3
18	M01525A001	WRIST PIN	3
19	24959A001	HOUSING, OIL SEAL	3
	22835A004	OIL SEAL	6
20	24958A000	RETAINER, OIL SEAL HOUSING	3
	06106A034	SCREW, ALLEN	6
	05059A434	GASKET, SEAL HOUSING	3
	24648A000	KIT FOR REF. NO. 19 & 20	1
21	M01643A000	SPRING	3
22	05059A058	GASKET	3
23	17481A002	PLUG, PIPE, MAGNETIC	1
24	06106A038	SCREW, CAP, 3/4"-10 UNC x 2-1/2", STEEL	4
	05454A003	LOCK WASHER	4
	20160F231	FLUID END, COMPLETE (DUCTILE IRON)	1
	20160F233	FLUID END, COMPLETE (ALUMINUM BRONZE)	1

Item	Eng. No	Description	Qty.
25	19105A008	SCREW, CAP, 5/8"-11 UNC x 2", STEEL	4
26	16654A006	SCREW, CAP, .551"-14 METRIC x 2-3/4"	3
27	18923A002	FOLLOWER	3
28	M01520A001	COVER-LOWER, BODY, CYLINDER	1
29	18922A000	PACKING, V-RINGS	3
30	18924A012	STUD, 2-9/16" x 2-1/16" x 1-1/2", SST, PISTON	3
31	18879A002	RETAINER	3
32	05030A128	WASHER	3
33	18920A000	SPRING	3
34	18921A000	RING	3
35	18639F002	BODY, CYLINDER	1
	18639F004	BODY, CYLINDER FOR AB PUMP	1
36	19109A046	NUT, HEX, 5/8"-11 UNC, STEEL	6
37	19109A072	NUT, HEX, 7/8"-14 UNF, STEEL	6
38	05659A560	STUD, 5/8"-11 UNC x 3-5/16"	6
39	05659A089	STUD, 7/8"-14 UNF X 4-1/2"	6
40	20848A000	CLAMP, VALVE CAP	3
41	20856A000	CLAMP, CYLINDER CAP	3
42	17390A000	CAP, VALVE	3
	17390A002	CAP, VALVE FOR AB PUMP	3
43	05876A064	O-RING, 2-3/8" x 2-9/16" x 3/32"	3
44	20849A000	CAP, CYLINDER	3
	20849A001	CAP, CYLINDER FOR AVAB PUMP	3
45	05876A096	O-RING, 3-1/4" x 3-1/2" x 1/8"	3
46	18925A003K	SUCTION VALVE AND SEAT COMPLETE	3
47	18925A004K	DISCHARGE VALVE AND SEAT COMPLETE	3
	18835A002	SEAT, VALVE	6
	18834A001	VALVE	6
	18463A000	SPRING, VALVE, SUCTION	3
	11829A000	SPRING, VALVE, DISCHARGE	3
	18833A001	RETAINER	6
	18832A000	SCREW, CAP 5/16"-24 UNF, SHOULDERED	6
48	20851A001	LINER, CYLINDER	3
	05876A095	O-RING, 2-3/4" x 2-15/16" x 3/32" FOR LINER	3
	05022A065	PLUG, 1-1/4" PIPE	1
	03210A010	PLUG, 3" PIPE	2
49	148850001	SCREW, MACHINE, 1/4"-20 UNC x 1/2"	2
	05030A020	WASHER	2
50	05022A063	PLUG, 1/2" PIPE	3
51	05022A064	PLUG, 1" PIPE	3

D65-20 HYDRAULIC DRIVE COMPONENTS

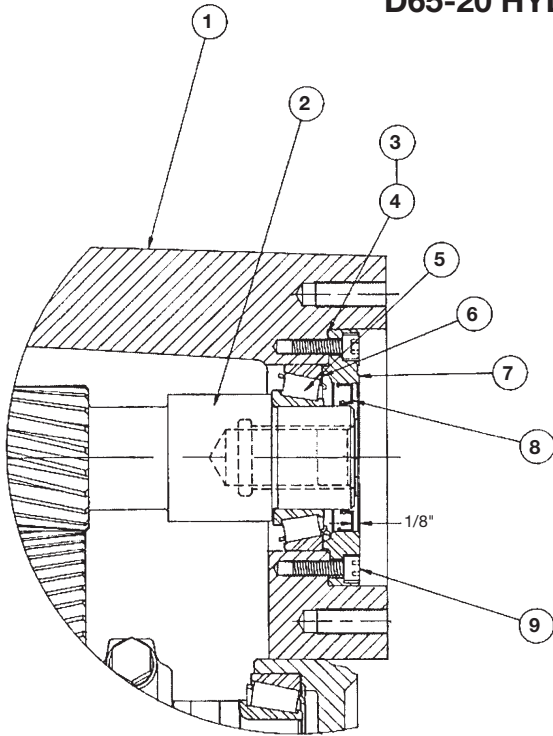

Item	Description	Qty.	Eng. No
1	CASE, GEAR	1	04625E100
2	SHAFT, PINION	1	20164B040
3	SHIM, GREEN, .003" THICK	4	05863A024
4	SHIM, PINK, .015" THICK	2	05863A023
5	CONE, BEARING	2	05674A020
6	CUP, BEARING	2	05675A019
7	CAP, BEARING & SEAL PLATE	2	04741B010
8	SEAL, OIL	2	05710A046
9	SCREW, CAP, SOCKET HEAD GRADE 8; 5/16"-24 UNF x 1" LONG (TORQUE 15 ft/lbs)	16	06106A048

DIMENSIONS, S.A.E., "C" FACE MOUNTING

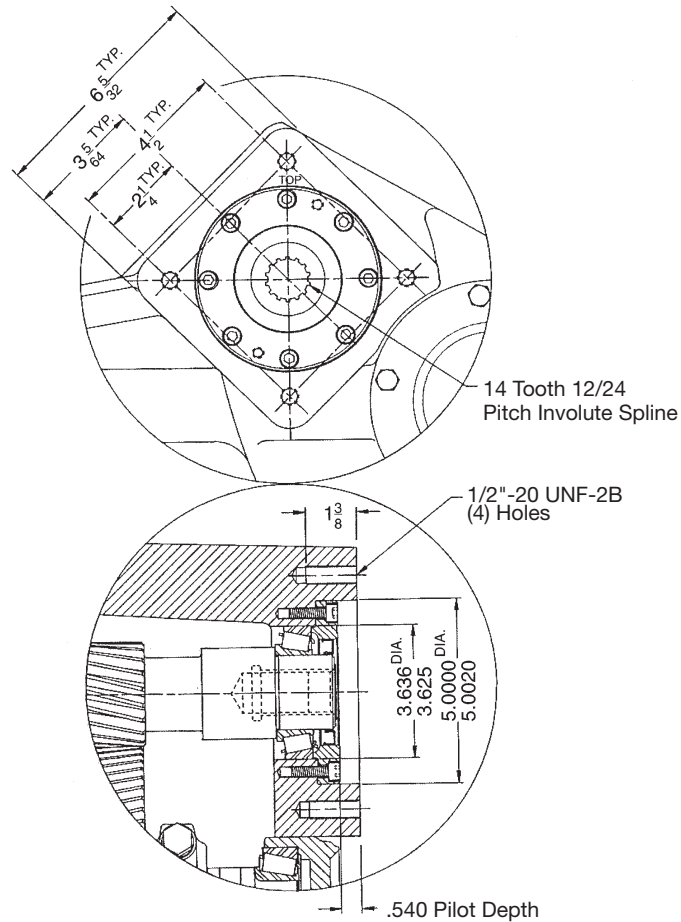

THE PUMP MUST BE INSTALLED WITH A PRESSURE RELIEF VALVE IN DISCHARGE LINE

TROUBLESHOOTING

Pump fails to build pressure with discharge closed					
Failure to hold pressure with discharge open					
Pump is noisy					
Pump gets hot					
Pressure gauge shows abnormal fluctuation					
POSSIBLE CAUSE OF PROBLEM					
1. Pump not primed					X
2. Valve closed in suction line			X		X
3. Suction line or sediment chamber clogged			X	X	X
4. Air leak in suction line			X	X	X
5. Pressure regulator valve badly worn or not properly adjusted				X	X
6. Broken valves or springs	X		X	X	
7. Pump packing or valves badly worn	X		X	X	
8. Pressure regulator bypassed by open #1 valve				X	X
9. Pump cylinder body cracked			X	X	X
10. Water in crankcase		X			
11. Worn connecting link inserts or wrist pin bushings		X	X		
12. Lack of oil in crankcase		X	X		
13. Foaming mixture in tank	X		X	X	
14. Regulator plunger sticking	X				
15. Foreign matter under pump valve	X		X	X	
16. Loose piston rod			X		
17. Improper preload of crankshaft bearings		X	X		

Explanation of the Service Chart

1. Pump priming is usually not necessary when the pump is installed correctly. However, there are certain conditions which may make it necessary to prime the pump to get the pumping action started. Priming will be required when it is impossible for the piston to displace the air in the pump and replace it with water. This could be caused by a high suction lift, the valves being stuck on the seat or by valves sticking due to extreme corrosion. A pump will not prime readily if someone has tampered with the valve springs causing them to exert undue pressure of the valve plates against the valve seats.
2. A gate valve is sometimes installed in the suction line between a tank or pressure line and the pump sediment chamber. It will shut off the supply source in order to clean the sediment chamber or to perform pump repairs. If this valve is partially or fully closed, it will interfere with the flow of water to the pump suction. This also may cause severe knocking and vibration of the pump because the water cannot flow into the cylinder cavities fast enough.
3. A sediment chamber should be installed in the suction line between the gate valve and the pump suction. The strainers in these sediment chambers are to allow a free flow of liquid to the pump. If the strainers become severely clogged, they will completely stop the flow of liquid to the pump.
4. Any piston pump operating at a high pressure will not perform properly or quietly if a mixture of air and water is allowed to enter the pump suction. A small air leak in the suction line will cause the pump to knock and vibrate excessively by allowing the pump to draw a certain amount of water mixed with air on each stroke of the piston. A large air leak will cause the pump to lose prime after which it cannot be reprimed until the air leak is stopped. Air leaks may occur at the joints of the suction line piping, at the gate valve in the suction line, at the gasket sealing the cap on the sediment chamber, by a crack in the suction wall of the cylinder body, or by air drawing past the packing on the suction stroke if the packing is badly worn.

5. If the pressure regulator internal bypass valve is worn, it will allow too much of the pump capacity to be bypassed and recirculated back to the tank. By examining the flow from this valve with the discharge turned on, it can be determined whether or not the valve is worn. If a heavy flow continues when the discharge is turned on, it is usually a good indication of a worn valve and should be replaced.
6. A broken pump valve or spring will often prevent one cylinder from functioning properly resulting in a rough pulsing discharge, a knocking sound and a loss of capacity. If not repaired immediately, the rough running pump can cause mechanical damage to itself or other system components.
7. Worn packing, valves or valve seats will cause a severe drop in pump capacity pressure. Worn packing is detected by water leakage and should be replaced immediately. Water getting in the pump crankcase will cause severe corrosion of the bearings and cause rapid wear. Worn valves can be detected by visual examination of each valve assembly. Abrasive liquid will cause wire cuts which begin as a very small groove, but increases rapidly once the valve starts to leak through this groove. If the valves are replaced as soon as they start to show this cutting action, it will prevent the valve seat from becoming cut in a similar manner.
8. If a portion of the pump delivery is allowed to bypass because the #1 control valve is not completely closed, there may not be adequate flow to develop full pressure. This will cause rapid wear in the control valve. Any excess flow should be bypassed only by the pressure regulator.
9. Pump cylinder bodies withstand an extreme amount of shock and pulsation while in operation. If the pump is allowed to freeze, by not being drained, the freezing may crack the cylinder body walls in almost any location. If the crack occurs on the suction valve or cylinder portion of the body, it may allow a small amount of air to enter on the suction stroke and cause noisy operation or a decrease in pumping capacity. If the crack develops in the walls between the cylinder cavities or discharge valve cavity, it may allow the water to flow from one cavity to the adjacent cavity and cause uneven displacement.
10. Water may accumulate in the pump crankcase from two sources; leakage of packing or an accumulation of condensation/moisture inside the crankcase due to changes in weather or the repeated heating and cooling of the pump. Pumps used consistently, running for a considerable period of time to heat the oil and other working parts, will not normally accumulate water by condensation. Replace the packing as soon as it starts to leak.
11. Worn connecting link bearings are caused by unusual or adverse operating conditions and are seriously affected by corrosion if water is present in the crankcase. They will wear out from overheating if the oil is not high quality or clean. Drain, clean and refill with new oil at the specified interval and prior to any storage period. Replace link inserts as soon as any wear is noticed to avoid damage to crankshaft journals.
12. Low oil in the crankcase can quickly cause failure of the pumps power end and result in extensive repairs. Oil level should be checked periodically during normal operation and during all maintenance work.
13. A foaming mixture will sometimes have the same effect as a small air leak in the suction line. This is because various quantities of the foam are drawn through the suction line into the pump disrupting the normal flow of water.
14. Pressure regulators can become sluggish due to the plunger sticking or fitting too tightly in the cylinder. This may happen by an accumulation of chemicals collecting in and around the plunger or from excessive corrosion of the plunger parts. To check this condition, remove and clean the plunger and cover the parts with a waterproof grease before assembling. The pressure regulator may chatter or vibrate excessively due to an unstable operation from nozzling in the high or low capacity range of the regulator. The range should be at least 50% to 90% of pump capacity.
15. If foreign matter becomes lodged between the pump valve and valve seat, a drastic drop in capacity and considerable surge or pulsation will occur in the discharge line. Examine each valve if this occurs.
16. Noisy pump operation may be caused by a loose piston rod in the crosshead. This noise usually has a regular cadence timed with each stroke. If this happens, always replace both the rod and the crosshead.
17. Increased preload to the crankshaft bearings will reduce bearing life, require more power and generate more heat. Insufficient preload may cause a knock, timed with the crankshaft rotation. Check for loose bolts on the crankshaft end caps or adjust shims to obtain proper bearing preload. Worn roller bearings will continue to run but will introduce wear particles into the oil.

D SERIES CROSSHEAD SEALS

24648A000 KIT

Field installation of these kits will require removal of the fluid end to replace the existing retainer and seals. On some fluid ends it may be necessary to hand grind I.D. of fluid end to fit new kit. The same spring and gasket is used to hold and seal the retainer.

The rod seal assembly contains two seals, and two oil seals with lips facing the power end. The oil seal can be replaced without taking the fluid end off by removing the piston and the cylinder liner to allow access to oil seal housing. Unscrew two Allen screws and place into the other two tapped holes. Gradually screw them in to push the oil seal housing off the retainer. After assembling new seals in the oil seal housing, an assembly thimble should be used on the end of the crosshead rod for sliding oil seal housing back into the retainer. Check gasket and replace if damaged. The thimble should be machined from high carbon steel and polished on the exterior to reduce the possibility of seal lip damage. Place two Allen screws into clearance holes and tighten snug.

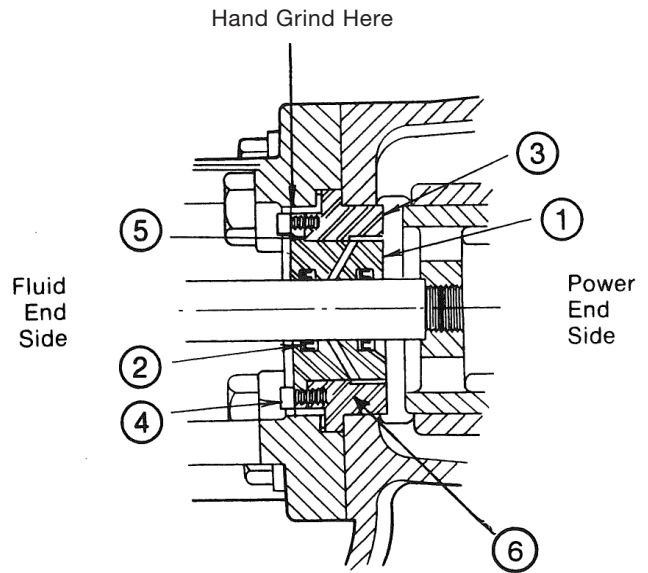

OIL SEAL HOUSING ASSEMBLY

RECOMMENDED THIMBLE

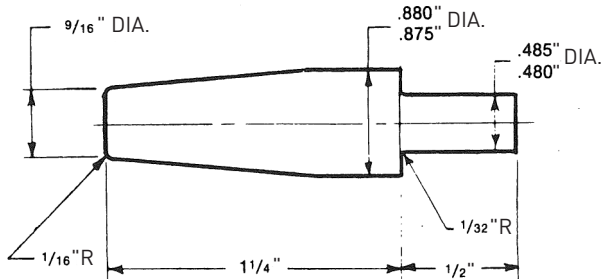

ITEM	DESCRIPTION	QTY.	ENG. NO
1	HOUSING, OIL SEAL	3	24959A001
2	OIL SEAL	6	22835A004
3	RETAINER, OIL SEAL HOUSING	3	24958A000
4	SCREW, ALLEN	6	06106A034
5	GASKET, SEAL HOUSING	3	05059A434
6	GASKET	3	05059A058

STANDARD LIMITED WARRANTY CENTRIFUGAL & RECIPROCATING PUMPS

Pentair Myers® warrants its products against defects in material and workmanship for a period of 12 months from the date of shipment from Pentair Myers or 18 months from the manufacturing date, whichever occurs first – provided that such products are used in compliance with the requirements of the Pentair Myers catalog and technical manuals.

During the warranty period and subject to the conditions set forth, Pentair Myers, at its discretion, will repair or replace to the original user, the parts that prove defective in materials and workmanship. Pentair Myers reserves the right to change or improve its products or any portions thereof without being obligated to provide such a change or improvement for prior sold and/or shipped units.

Seals, piston cups, packing, plungers, liners and valves used for handling clear, fresh, nonaerated water at a temperature not exceeding 120°F are warranted for ninety days from date of shipment. All other applications are subject to a thirty day warranty. Accessories such as motors, engines and auxiliary equipment are warranted by the respective manufacturer and are excluded in this standard warranty. Under no circumstance will Pentair Myers be responsible for the cost of field labor, travel expenses, rented equipment, removal/reinstallation costs or freight expenses to and from the factory or an authorized Pentair Myers service facility.

This limited warranty will not apply: (a) to defects or malfunctions resulting from failure to properly install, operate or maintain the unit in accordance with the printed instructions provided; (b) to failures resulting from abuse, accident or negligence; (c) to normal maintenance services and parts used in connection with such service; (d) to units that are not installed in accordance with applicable local codes, ordinances and good trade practices; (e) if the unit is moved from its original installation location; (f) if unit is used for purposes other than for what it is designed and manufactured; (g) to any unit that has been repaired or altered by anyone other than Pentair Myers or an authorized Pentair Myers service provider; (h) to any unit that has been repaired using non factory specified/OEM parts.

Warranty Exclusions: PENTAIR MYERS MAKES NO EXPRESS OR IMPLIED WARRANTIES THAT EXTEND BEYOND THE DESCRIPTION ON THE FACE HEREOF. PENTAIR MYERS SPECIFICALLY DISCLAIMS THE IMPLIED WARRANTIES OF MERCHANTABILITY AND FITNESS FOR ANY PARTICULAR PURPOSE.

Liability Limitation: IN NO EVENT SHALL PENTAIR MYERS BE LIABLE OR RESPONSIBLE FOR CONSEQUENTIAL, INCIDENTAL OR SPECIAL DAMAGES RESULTING FROM OR RELATED IN ANY MANNER TO ANY PENTAIR MYERS PRODUCT OR PARTS THEREOF. PERSONAL INJURY AND/OR PROPERTY DAMAGE MAY RESULT FROM IMPROPER INSTALLATION. PENTAIR MYERS DISCLAIMS ALL LIABILITY, INCLUDING LIABILITY UNDER THIS WARRANTY, FOR IMPROPER INSTALLATION. PENTAIR MYERS RECOMMENDS INSTALLATION BY PROFESSIONALS.

Some states do not permit some or all of the above warranty limitations or the exclusion or limitation of incidental or consequential damages and therefore such limitations may not apply to you. No warranties or representations at any time made by any representatives of Pentair Myers shall vary or expand the provision hereof.



MYERS®
MYERS® APLEX SERIES

1101 MYERS PARKWAY
ASHLAND, OHIO, USA 44805
419-289-1144

WWW.FEMYERS.COM

Warranty Rev. 12/13