

# FRESHPOINT<sup>®</sup> F3000

## THREE STAGE FILTRATION SYSTEMS



F3000-B2M, (with filter life monitor) shown

### APPLICATIONS

- ◆ Drinking water

### FEATURES • BENEFITS

- ◆ Effortless click-in cartridge change-outs
- ◆ Color-coded cartridges help maintain proper filter sequence
- ◆ 3/8" push fittings for easy installation
- ◆ Optional remote cartridge timer provides visual filter replacement notification (*Model F3000-B2M only*)

### MODELS

- ◆ F3000-B2M (Includes filter life monitor)

### INSTALLATION TIPS

- ◆ Choose a mounting location suitable to support the full weight of the system when operating.
- ◆ Install vertically with the cartridge hanging down.
- ◆ System may be installed with cartridge flush to the baseboard if desired as the mechanical assist lever pushes cartridges straight out.
- ◆ Magnetic timer may be removed from system and placed in alternative locations such as on refrigerator.

### OPERATION TIPS

- ◆ Replace cartridge every 675 gallons or 1 year (or if flow has diminished).
- ◆ System designed with integrated check valves so cold water line does not need to be shut-off to perform cartridge change-outs.

### INCLUDES

- ◆ Side faucet
- ◆ Installation kit
- ◆ Installation and operation manual

# FRESHPOINT THREE STAGE FILTRATION SYSTEMS

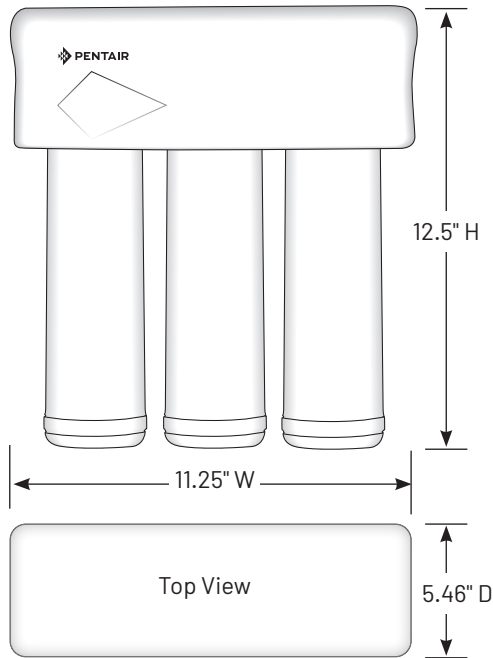

## SPECIFICATIONS

- ◆ **System** (Model/Part No.)  
F3000-B2M/158854  
F3000-B2B/158840
- ◆ **Inlet Size**  
3/8" QC
- ◆ **Dimensions**  
12.5" H x 11.25" W x 5.46" D  
(317 mm x 285 mm x 139 mm)
- ◆ **System Weight**  
6 lbs
- ◆ **Contaminant Reduction**  
Chlorine Taste & Odor, Lead, Atrazine, Lindane, Nominal Particulate, Class I, VOC's, PFOA/PFOS, Cyst: NSF/ANSI Standard 53 certified to reduce cysts such as *Cryptosporidium* and *Giardia* by mechanical means.
- ◆ **Micron Rating**  
0.50
- ◆ **Approximate Filter Life\***  
Up to 1 Year
- ◆ **Capacity**  
675 Gallons (2555.15 liters)
- ◆ **System Production Rate**  
0.60 gpm (2.27 Lpm)  
(Side Faucet Required)
- ◆ **Certifications**  
NSF/ANSI Standard 53  
CSA Standard B483.1
- ◆ **Feed Pressure Range**  
40 - 100 psi (2.75 - 6.89 bar)
- ◆ **Temperature Range**  
40 - 100°F (4.4 - 37.8°C)
- ◆ **Replacement Cartridges**  
(Model/Part No.)  
F1S5-RC/655116-96  
F2B2-RC/655126-96 (twin pack)

\* Filter life dependent on gallon usage and overall incoming water quality.

EPA Est. No. 082989-CHN-001



The Models F3000-B2B and F3000-B2M are Tested and Certified by NSF International against NSF/ANSI Standards 42, 53 and CSA B483.1 for the reduction of substances specified in the service manual or at [www.nsf.org](http://www.nsf.org).



The Models F3000-B2B and F3000-B2M are certified by IAPMO R&T against NSF/ANSI 53 for the reduction of perfluorooctanoic acid (PFOA) and perfluorooctane sulfonate (PFOS).



13845 Bishops Dr. | Suite 200 | Brookfield, WI 53005 | United States  
P: 262.238.4400 | Customer Service: 800.279.9404 | [tech-support@pentair.com](mailto:tech-support@pentair.com) | [pentair.com](http://pentair.com)

All indicated Pentair trademarks and logos are property of Pentair. Third party registered and unregistered trademarks and logos are the property of the  
© 2022 Pentair. All rights reserved.